

2933

10594

19567

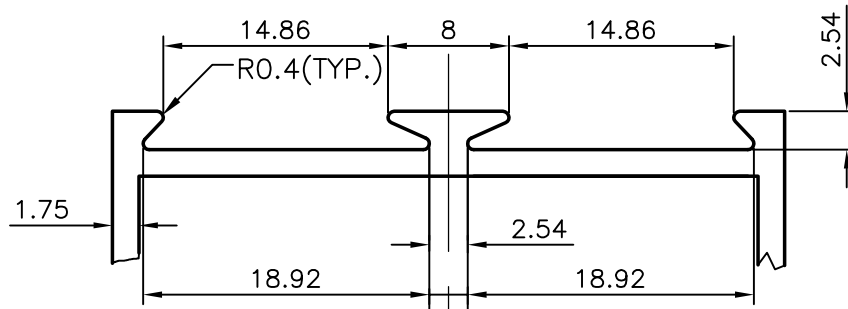

DETAIL AT "X"

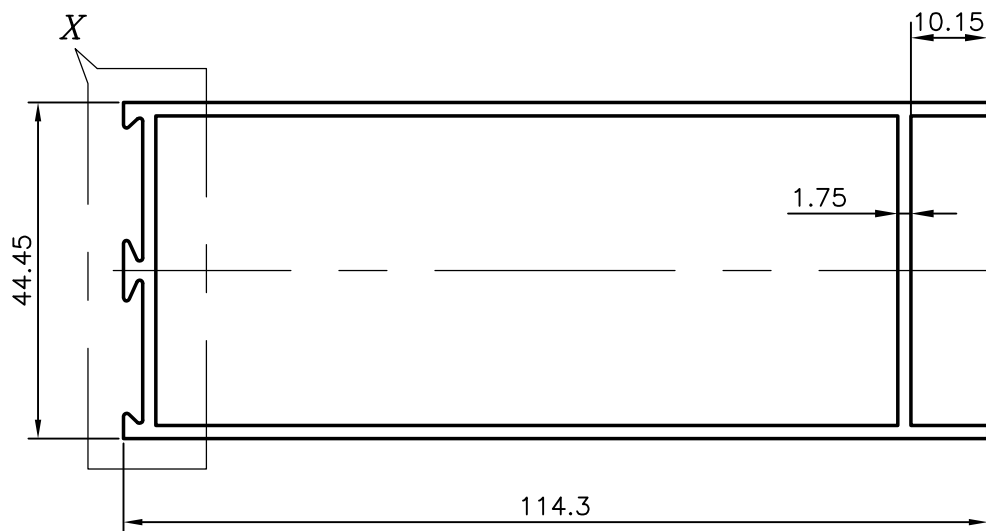

NO. OF PIECES IN 100 kgs = 18 (AVERAGE)

GENERAL WALL THICKNESS = 1.75mm



SYMBOL OF QUALITY
AN ISO 9001 COMPANY

JINDAL ALUMINIUM LTD.
BANGALORE-560073 (INDIA)

	NAME	DATE
DRAWN	RAGHAVENDRA	30-10-2006
CHECKED		
APPROVED		

1. ALL DIMENSIONS ARE IN mm.
2. ROUND OFF ALL SHARP CORNERS WITH 0.40 mm.
3. TOLERANCES WILL BE AS PER IS:6477-1983 UNLESS OTHERWISE SPECIFIED

SCALE	1:1
AREA mm ²	561.587
PERIMETER mm.	359
WEIGHT kg/m	1.516

PARTY'S NAME	GENERAL CATEGORY, DELHI MARKET	DRAWING No.	SECTION No.
PARTY'S DRAWING No.	LIGHTER SECTION OF 4529	2933	2933
ALLOY & TEMPER	HE9 WP	10594	10594
DESCRIPTION	DOOR SECTION	19567	19567