

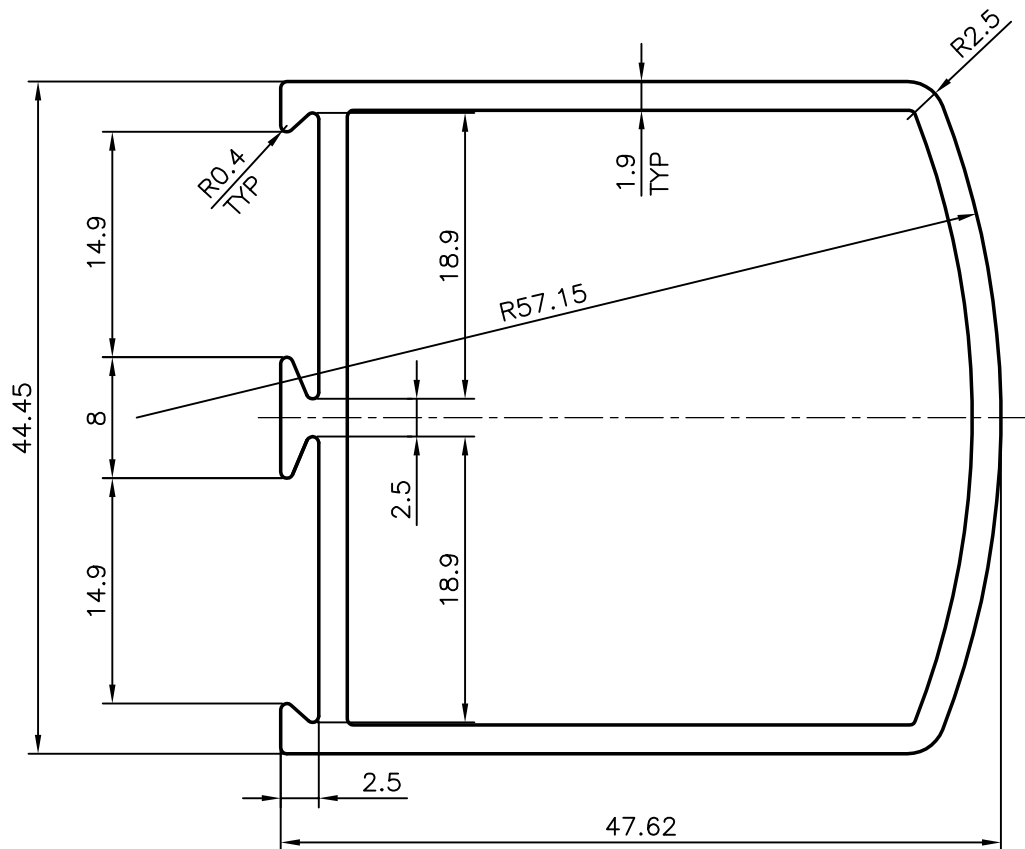

2937
10523
19570

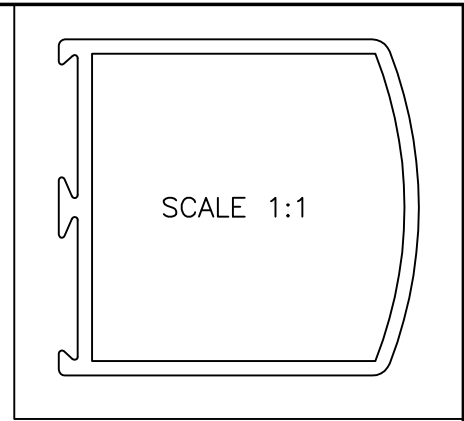

GENERAL WALL THICKNESS = 1.90mm
 NO. OF PIECES IN 100 kgs = 30 (AVERAGE)

 SYMBOL OF QUALITY AN ISO 9001 COMPANY	JINDAL ALUMINIUM LTD. BANGALORE-560073 (INDIA)	NAME	DATE
		DRAWN	PRASHANT 30-10-2006
1. ALL DIMENSIONS ARE IN mm. 2. ROUND OFF ALL SHARP CORNERS WITH 0.40 mm. 3. TOLERANCES WILL BE AS PER IS:6477-1983 UNLESS OTHERWISE SPECIFIED		CHECKED	
		APPROVED	
PARTY'S NAME: -		SCALE	2:1
		AREA mm ²	337.722
PARTY'S DRAWING No. LIGHTER SECTION OF 4505		PERIMETER mm.	196.112
		WEIGHT kg/m	0.911
ALLOY & TEMPER: HE9 WP		DRAWING No.	SECTION No.
		2937	2937
DESCRIPTION: DOOR SECTION		10523	10523
		19570	19570