

2938
10543
19571

GENERAL WALL THICKNESS = 1.95mm
NO OF PIECES IN 100 kgs:- 28 (AVERAGE)

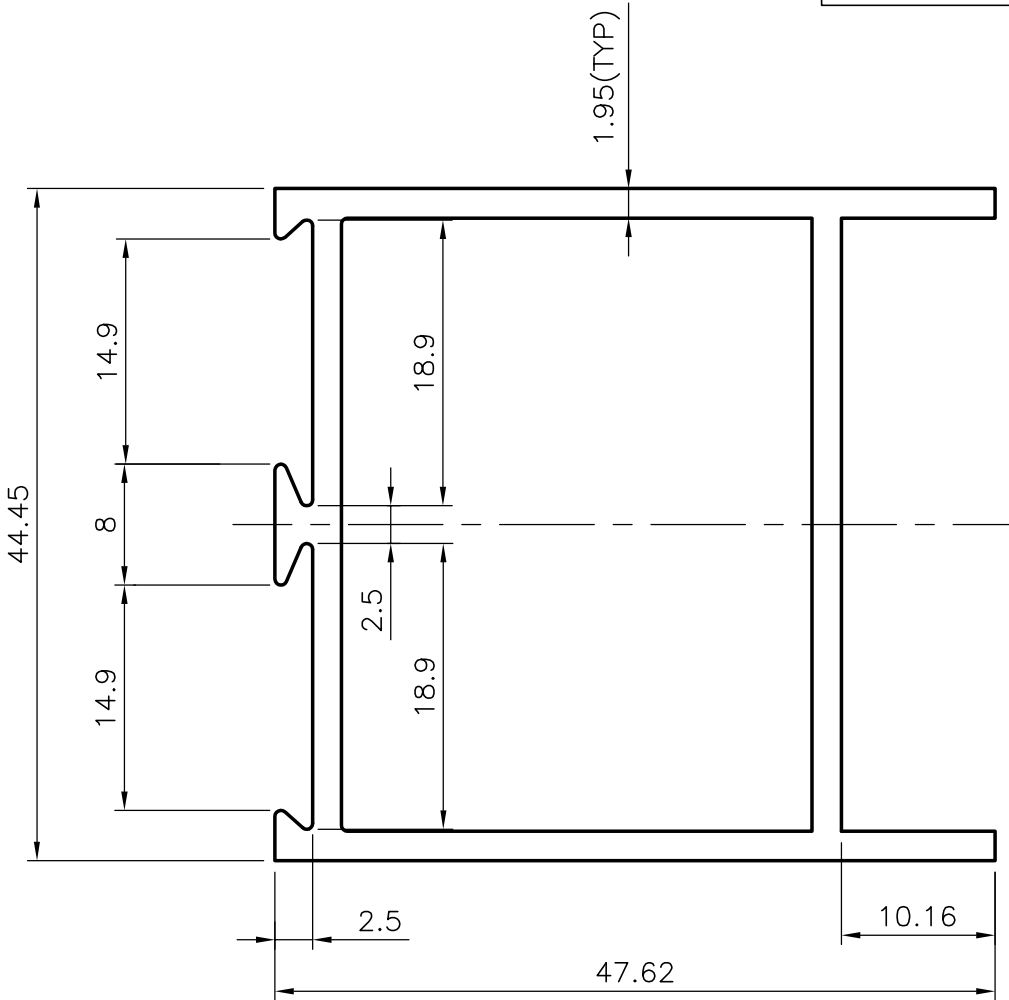
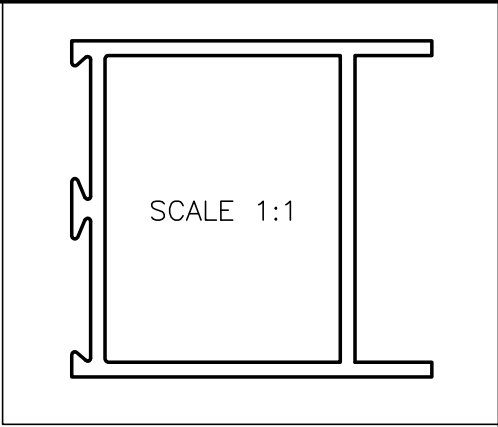

JINDAL ALUMINIUM LTD.
BANGALORE-560073 (INDIA)

	NAME	DATE
DRAWN	RAGHAVENDRA	25-11-01
CHECKED		
APPROVED		

1. ALL DIMENSIONS ARE IN mm.
2. ROUND OFF ALL SHARP CORNERS WITH 0.40 mm.
3. TOLERANCES WILL BE AS PER I.S 6477-1983 UNLESS OTHERWISE SPECIFIED

PARTY'S NAME	-
PARTY'S DRAWING No.	LIGHTER SECTION OF 19503
ALLOY & TEMPER	HE9 WP
DESCRIPTION	DOOR SECTION

SCALE	2:1 & 1:1
WEIGHT kg/m	0.974
PERIMETER	225.38mm
SECTION No.	19571
DRAWING No.	19571