

2939

10553

19572

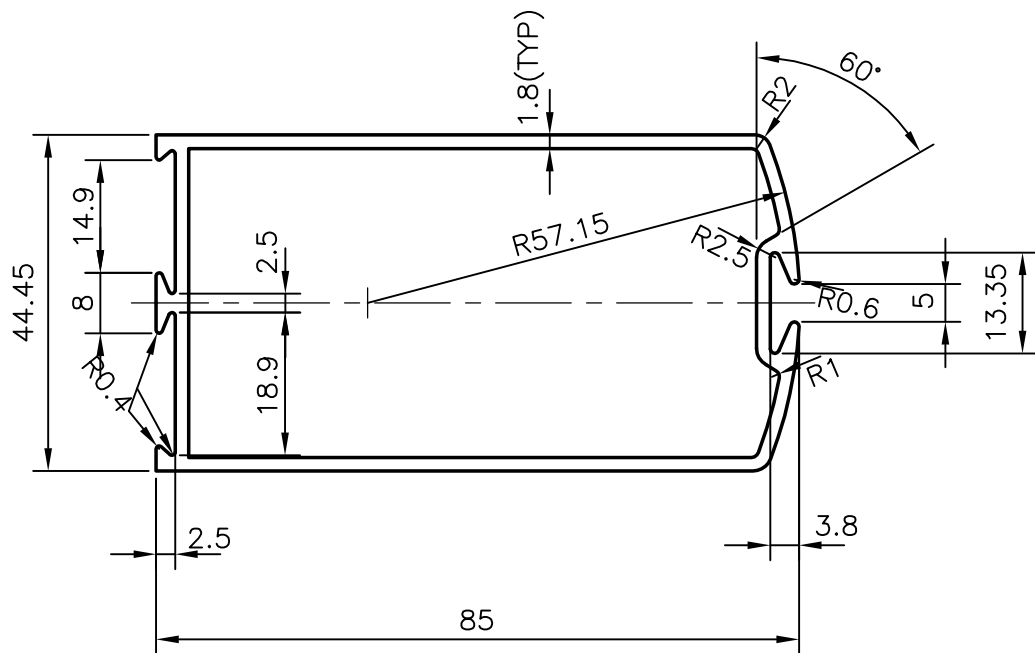

1. GENERAL WALL THICKNESS :- 1.80 mm.
2. NO. OF PIECES IN 100 kgs :- 21 (AVERAGE)



SYMBOL OF QUALITY  
AN ISO 9002 COMPANY

**JINDAL ALUMINIUM LTD.**  
BANGALORE-560073 (INDIA)

	NAME	DATE
DRAWN	J.P.KAUSHIK	12-09-2005
CHECKED		
APPROVED		

1. ALL DIMENSIONS ARE IN mm.
2. ROUND OFF ALL SHARP CORNERS WITH 0.40 mm.
3. TOLERANCES WILL BE AS PER IS: 6477-1983 UNLESS OTHERWISE SPECIFIED

SCALE	1:1
AREA mm <sup>2</sup>	483.066
PERIMETER mm.	291.537
WEIGHT kg/m	1.301

PARTY'S NAME	-	DRAWING No.	2939	SECTION No.	2939
PARTY'S DRAWING No.	LIGHTER OF SECTION NO. 4526		10553		10553
ALLOY & TEMPER	HEP WP		19572		19572
DESCRIPTION	DOOR VERTICAL				