

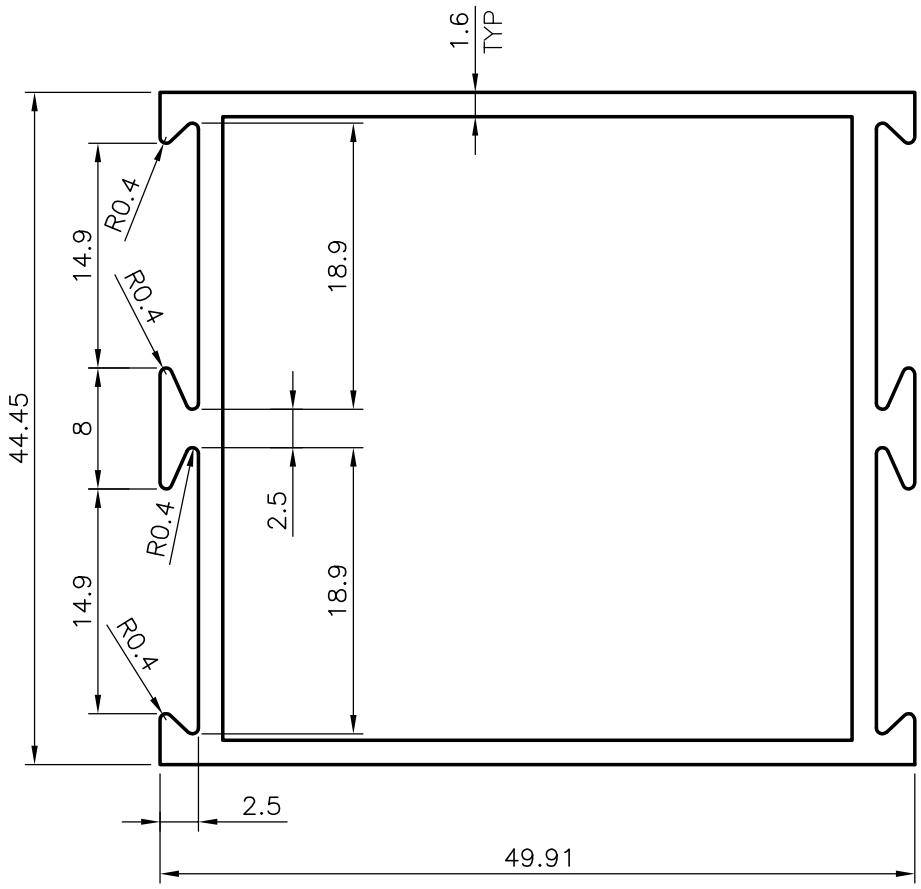

2950
11083
19575

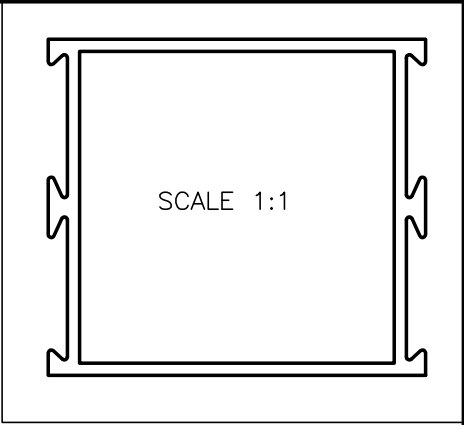

GENERAL WALL THICKNESS = 1.60mm
 NO. OF PIECES IN 100 kgs;- 31 (AVERAGE)

 SYMBOL OF QUALITY AN ISO 9001 COMPANY	JINDAL ALUMINIUM LTD. BANGALORE-560073 (INDIA)	NAME		DATE
		DRAWN	RAGHAVENDRA	28-06-2005
1. ALL DIMENSIONS ARE IN mm. 2. ROUND OFF ALL SHARP CORNERS WITH 0.40 mm. 3. TOLERANCES WILL BE AS PER IS:6477-1983 UNLESS OTHERWISE SPECIFIED		CHECKED		
		APPROVED		
PARTY'S NAME		SCALE		2:1
		AREA mm ²		329.66
PARTY'S DRAWING No.		PERIMETER mm.		231.12
		WEIGHT kg/m		0.882
ALLOY & TEMPER		DRAWING No.		SECTION No.
		2950		2950
DESCRIPTION		11083		11083
		19575		19575
DOOR SECTION				