

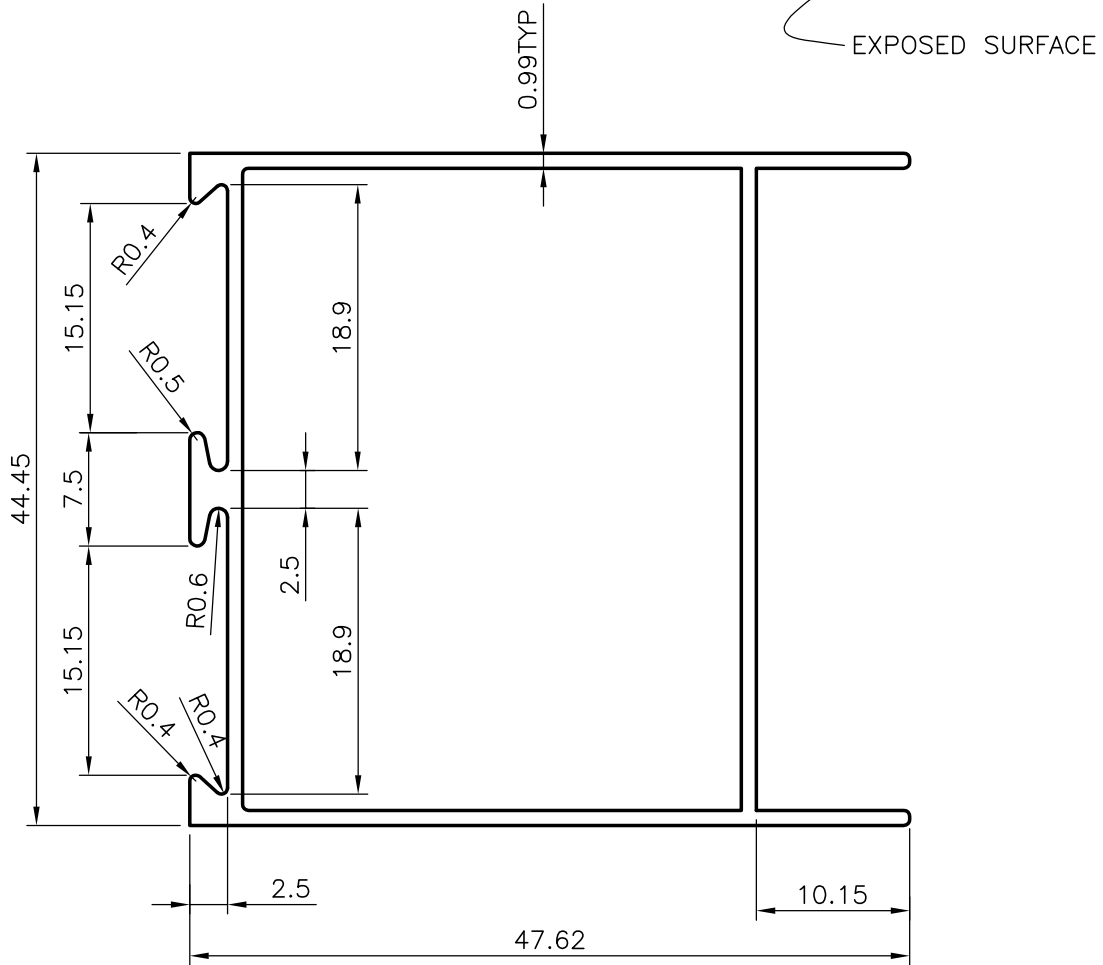

P-3627
2953
10546
19576

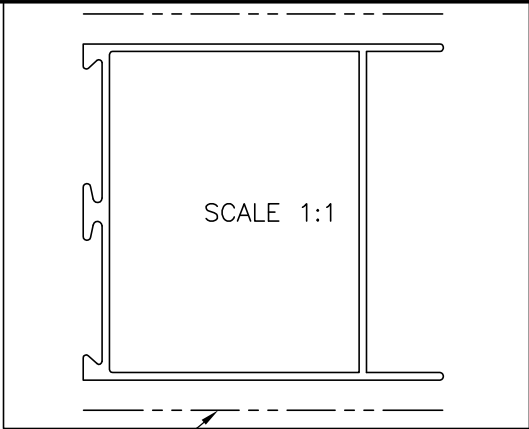

GENERAL WALL THICKNESS = 0.99mm

 SYMBOL OF QUALITY AN ISO 9001 COMPANY	<b>JINDAL ALUMINIUM LTD.</b> BANGALORE-560073 (INDIA)	NAME		DATE
		DRAWN	RAGHAVENDRA	23-12-2006
1. ALL DIMENSIONS ARE IN mm. 2. ROUND OFF ALL SHARP CORNERS WITH 0.40 mm. 3. TOLERANCES WILL BE AS PER IS:6477-1983 UNLESS OTHERWISE SPECIFIED		SCALE		2:1
		AREA mm <sup>2</sup>		198.981
PARTY'S NAME GENERAL CATEGORY, COCHIN MARKET		PERIMETER mm.		224.04
		WEIGHT kg/m		0.537
PARTY'S DRAWING No. AS PER SPECIFICATION		DRAWING No.		SECTION No.
		P-3627		-
ALLOY & TEMPER HE9 WP		2953		2953
		10546		10546
DESCRIPTION DOOR SECTION		19576		19576