

P-4747
14633
19585

GENERAL WALL THICKNESS = 1.90±0.20

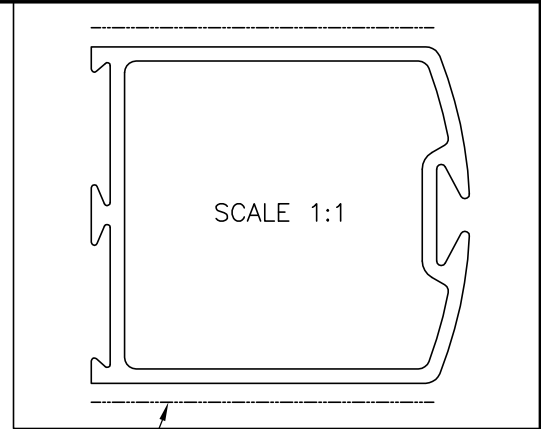

EXPOSED SURFACE
BETTER FINISH REQUIRED

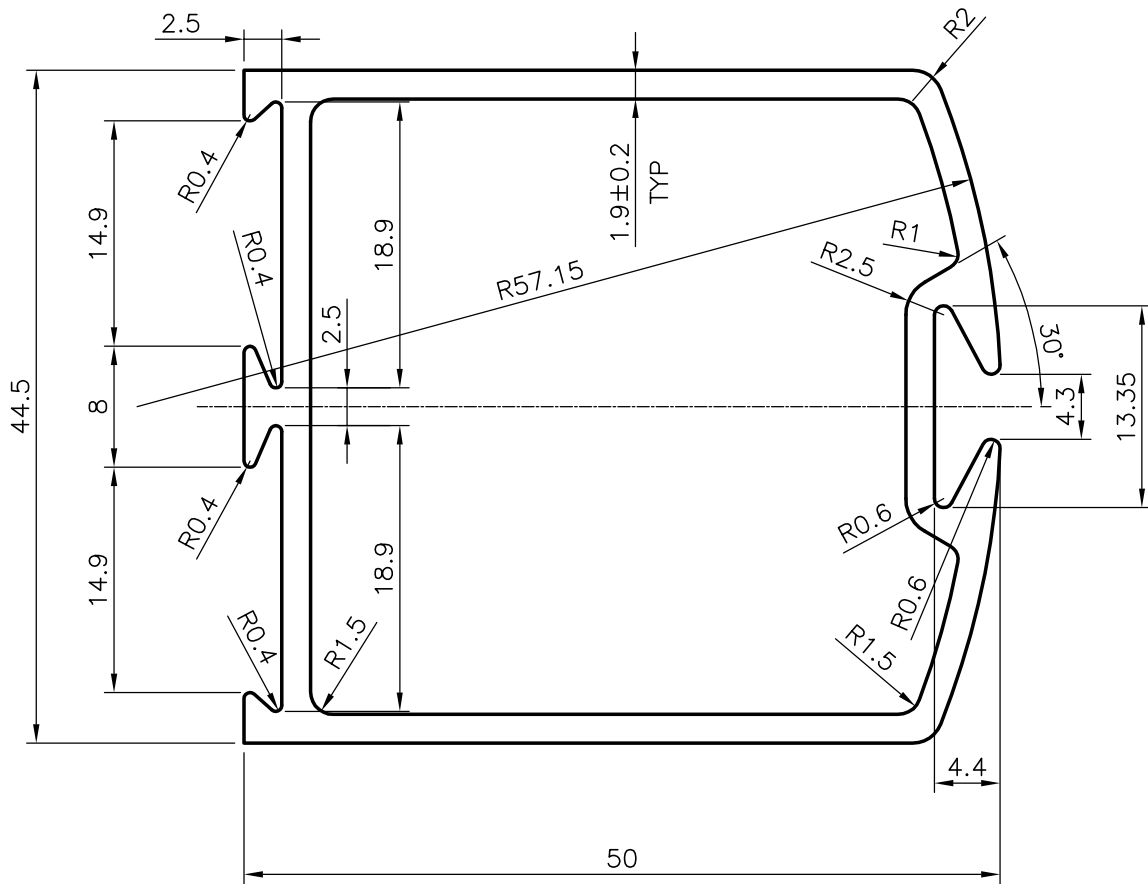

JINDAL ALUMINIUM LTD.
BANGALORE-560073 (INDIA)

	NAME	DATE
DRAWN	RAGHAVENDRA	25-02-2004
CHECKED		
APPROVED		

1. ALL DIMENSIONS ARE IN mm.
2. ROUND OFF ALL SHARP CORNERS WITH 0.40 mm.
3. TOLERANCES WILL BE AS PER IS:6477-1983 UNLESS OTHERWISE SPECIFIED

SCALE	2:1
AREA mm ²	381.647
PERIMETER mm.	223.43
WEIGHT kg/m	1.030

PARTY'S NAME	GENERAL CATEGORY ,, CHENNAI MARKET
PARTY'S DRAWING No.	AS PER SKETCH (LIGHTER OF 4595)
ALLOY & TEMPER	HE9 WP
DESCRIPTION	DOOR SECTION

DRAWING No.	SECTION No.
P-4747	-
14633	14633
19585	19585