

P-5184-1

19589

GENERAL WALL THICKNESS = 1.30 ± 0.20

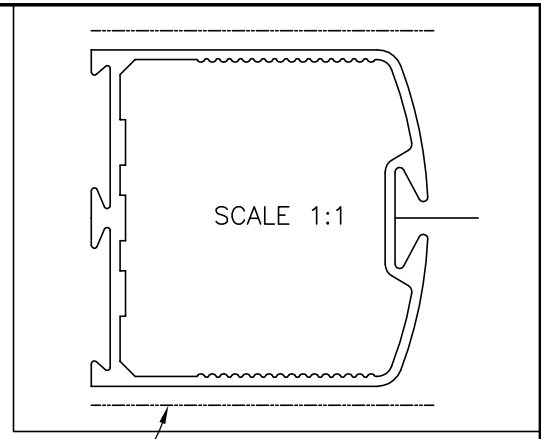

EXPOSED SURFACE
BETTER FINISH REQUIRED

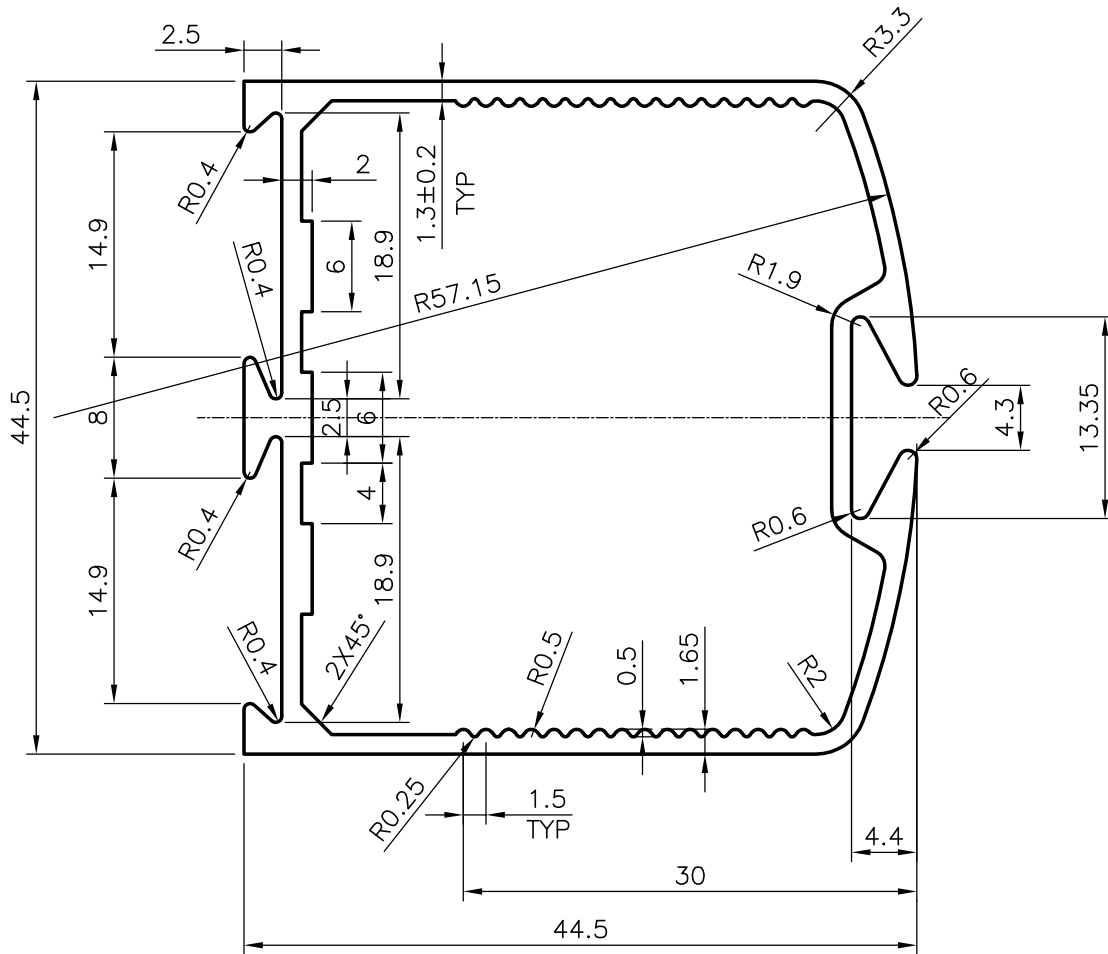

SYMBOL OF QUALITY
AN ISO 9002 COMPANY

JINDAL ALUMINIUM LTD.
BANGALORE-560073 (INDIA)

	NAME	DATE
DRAWN	RAGHAVENDRA	01-01-2005
CHECKED		
APPROVED		

1. ALL DIMENSIONS ARE IN mm.
2. ROUND OFF ALL SHARP CORNERS WITH 0.40 mm.
3. TOLERANCES WILL BE AS PER IS:6477-1983 UNLESS OTHERWISE SPECIFIED

SCALE	2:1
AREA mm ²	287.79
PERIMETER mm.	211.989
WEIGHT kg/m	0.777

PARTY'S NAME	GENERAL CATEGORY ,, CHENNAI MARKET
PARTY'S DRAWING No.	DRAWING NO-1812-A
ALLOY & TEMPER	HE9 WP
DESCRIPTION	DOOR SECTION

DRAWING No.	SECTION No.
P-5184-1	-
19589	19589