

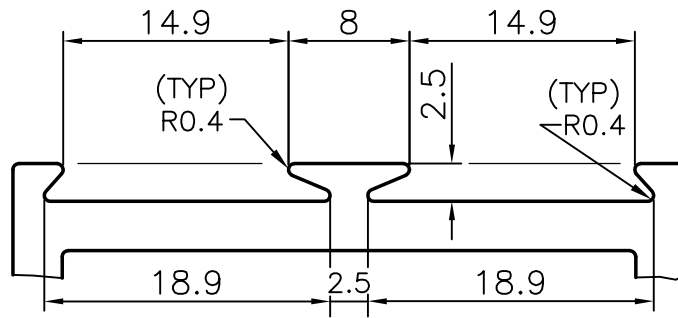

P-5413

19592

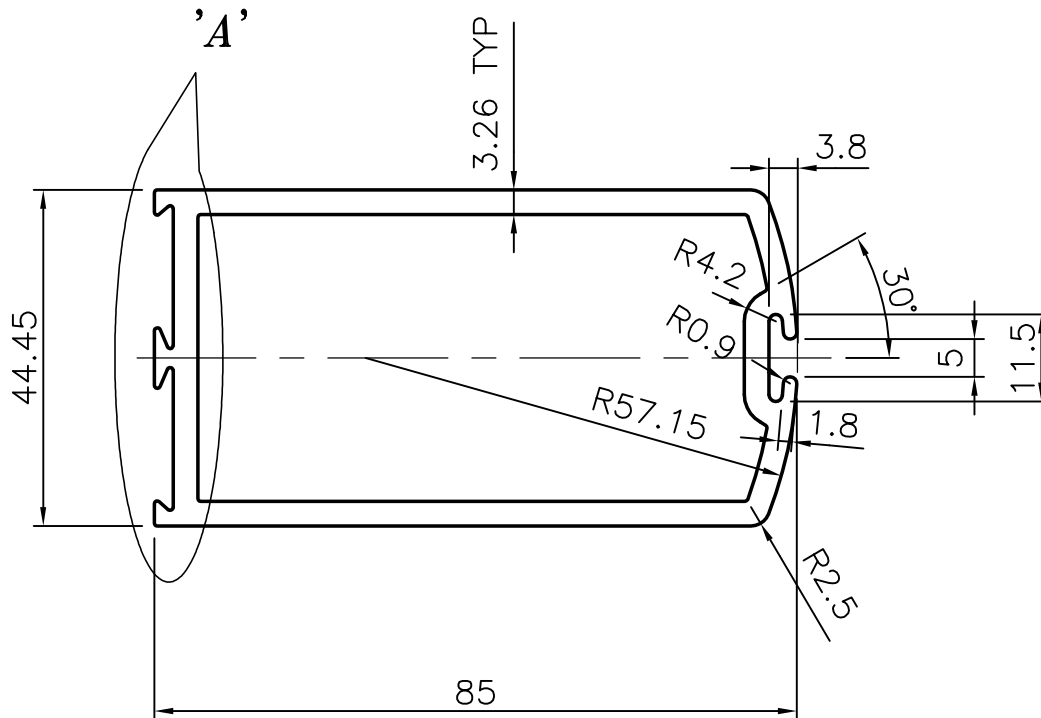

DETAIL A



 SYMBOL OF QUALITY AN ISO 9001 COMPANY	JINDAL ALUMINIUM LTD. BANGALORE-560073 (INDIA)	NAME		DATE	
		DRAWN	MALINGAPPA	02.04.2005	
		CHECKED			
1. ALL DIMENSIONS ARE IN mm. 2. ROUND OFF ALL SHARP CORNERS WITH 0.40 mm. 3. TOLERANCES WILL BE AS PER IS: 6477-1983 UNLESS OTHERWISE SPECIFIED		SCALE		1:1, 2:1	
PARTY'S NAME		GENERAL CATEGORY, DELHI MARKET		AREA mm ²	814.735
		PARTY'S DRAWING No.		AS PER SAMPLE	PERIMETER mm.
ALLOY & TEMPER		HE9 WP		WEIGHT kg/m	2.200
		DESCRIPTION		DOOR SECTION	DRAWING No.
				P-5413	-
				19592	19592