

P-5742

19595

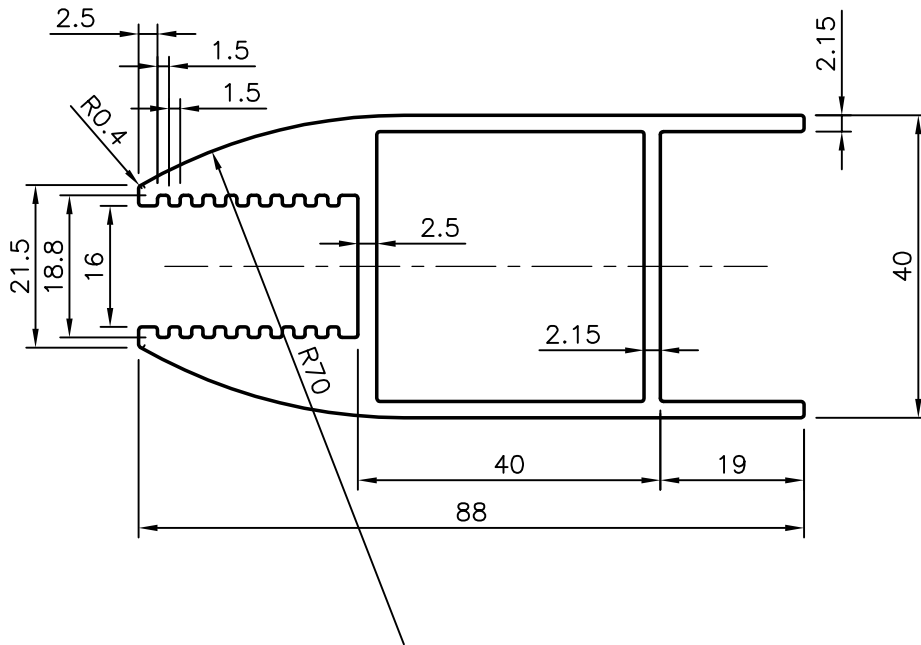

1. WEIGHT PER 3658 mm. LONG PIECE:- 8.500 kg (APPROX.)



SYMBOL OF QUALITY
AN ISO 9001 COMPANY

JINDAL ALUMINIUM LTD.
BANGALORE-560073 (INDIA)

| | NAME | DATE |
|----------|-------------|------------|
| DRAWN | RAGHAVENDRA | 28-07-2005 |
| CHECKED | | |
| APPROVED | | |

1. ALL DIMENSIONS ARE IN mm.
2. ROUND OFF ALL SHARP CORNERS WITH 0.40 mm.
3. TOLERANCES WILL BE AS PER IS:6477-1983 UNLESS OTHERWISE SPECIFIED

| | |
|----------------------|---------|
| SCALE | 1:1 |
| AREA mm ² | 861.229 |
| PERIMETER mm. | 373.411 |
| WEIGHT kg/m | 2.325 |

| | | | | | |
|---------------------|---------------------------------|-------------|--------|-------------|-------|
| PARTY'S NAME | GENERAL CATEGORY, COCHIN MARKET | DRAWING No. | P-5742 | SECTION No. | - |
| PARTY'S DRAWING No. | LIGHTER OF SECTION NO. 19546 | | 19595 | | 19595 |
| ALLOY & TEMPER | HE9 WP | | | | |
| DESCRIPTION | ARCHITECTURAL SECTION | | | | |