

P-5693-1

19596

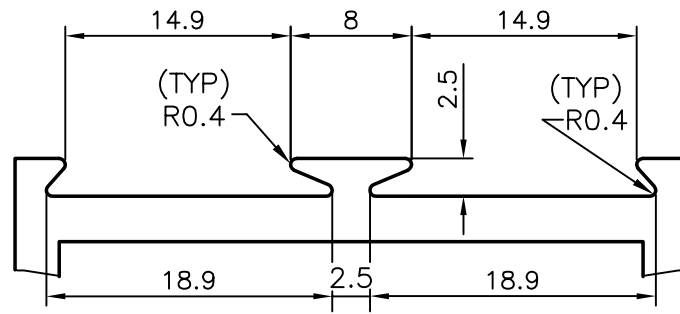

**DETAIL A**

SCALE:- 2:1

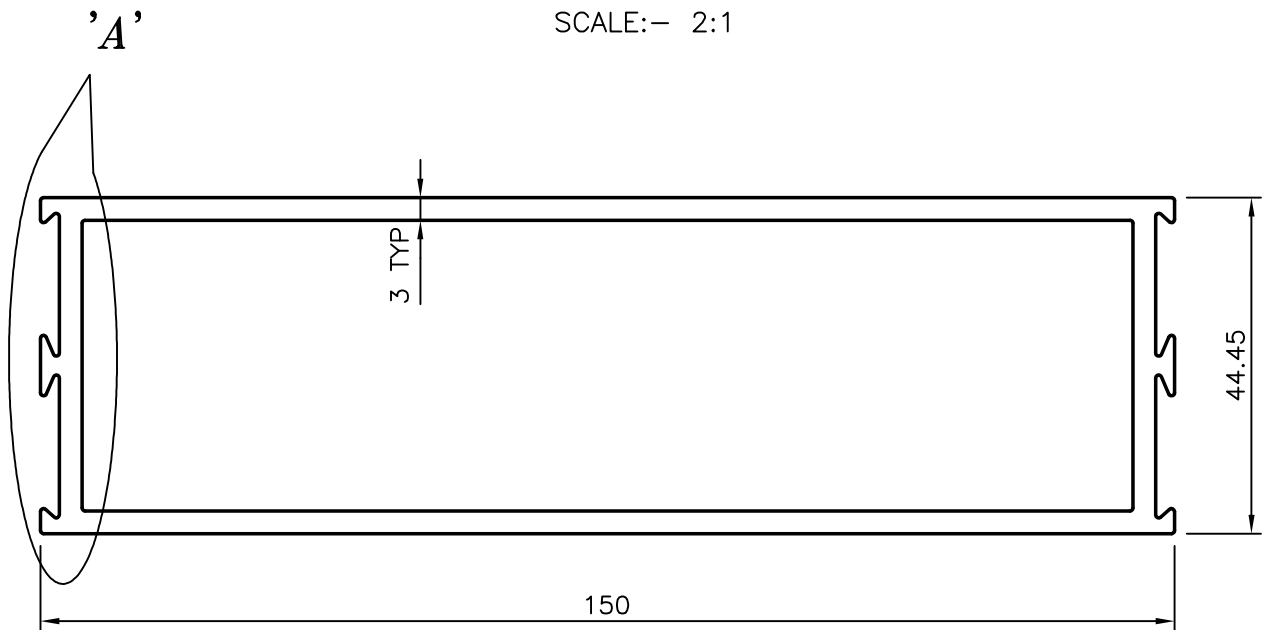

1. GENERAL WALL THICKNESS :- 3.0 mm.



SYMBOL OF QUALITY  
AN ISO 9001 COMPANY

**JINDAL ALUMINIUM LTD.**  
BANGALORE-560073 (INDIA)

	NAME	DATE
DRAWN	MALINGAPPA	19-01-2006
CHECKED		
APPROVED		

1. ALL DIMENSIONS ARE IN mm.
2. ROUND OFF ALL SHARP CORNERS WITH 0.40 mm.
3. TOLERANCES WILL BE AS PER IS:6477-1983 UNLESS OTHERWISE SPECIFIED

SCALE	1:1
AREA mm <sup>2</sup>	1153.95
PERIMETER mm.	430.049
WEIGHT kg/m	3.116

PARTY'S NAME GENERAL CATEGORY, LUCKNOW MARKET

PARTY'S DRAWING No. AS PER DRAWING

ALLOY & TEMPER HE9 WP

DESCRIPTION DOOR SECTION-MID RAIL

DRAWING No.	SECTION No.
P-5693-1	-
19596	19596