

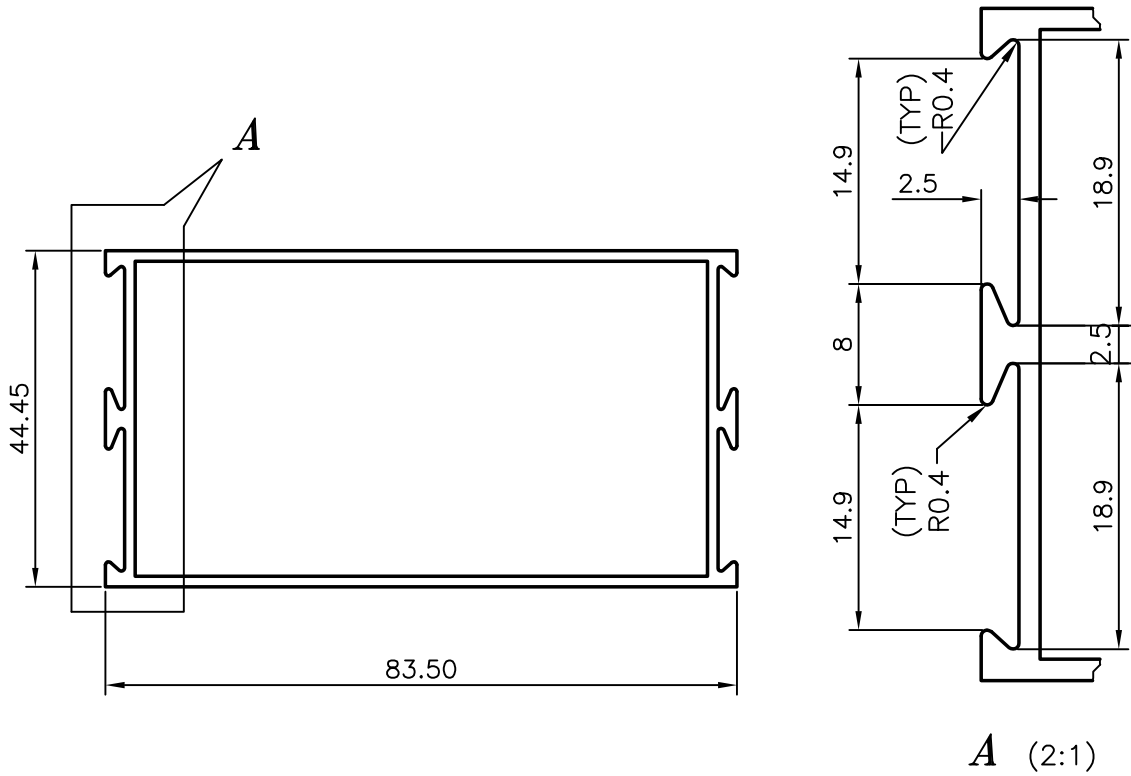

P-6348

19599



1. GENERAL WALL THICKNESS :- 1.40 mm.

 SYMBOL OF QUALITY AN ISO 9001 COMPANY	JINDAL ALUMINIUM LTD. BANGALORE-560073 (INDIA)	NAME		DATE
		DRAWN	J.P.KAUSHIK	22-04-2006
1. ALL DIMENSIONS ARE IN mm. 2. ROUND OFF ALL SHARP CORNERS WITH 0.4 mm. 3. TOLERANCES WILL BE AS PER IS:6477-1983 UNLESS OTHERWISE SPECIFIED		CHECKED		
		APPROVED		
PARTY'S NAME GENERAL CATEGORY		SCALE		1:1
		AREA mm ²		389.67
PARTY'S DRAWING No. LIGHTER OF SECTION NO 19551		PERIMETER mm.		297.736
		WEIGHT kg/m		1.052
ALLOY & TEMPER HE9 WP		DRAWING No.		SECTION No.
		P-6348		-
DESCRIPTION DOOR SECTION		19599		19599