

P-11166

19613

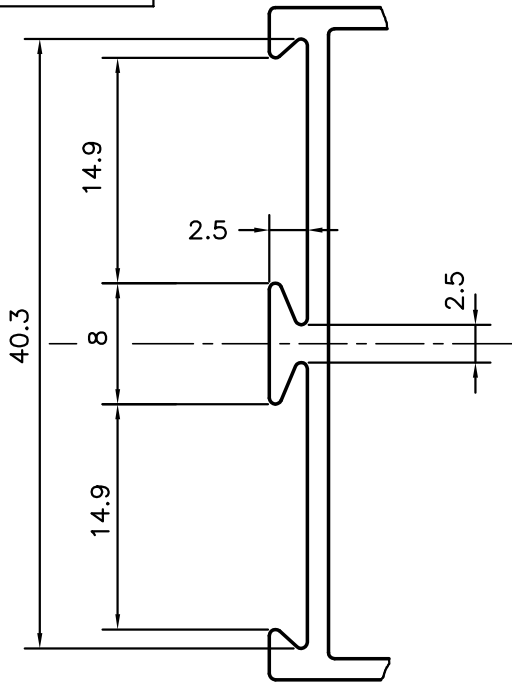

SCALE 3:1  
DETAIL B

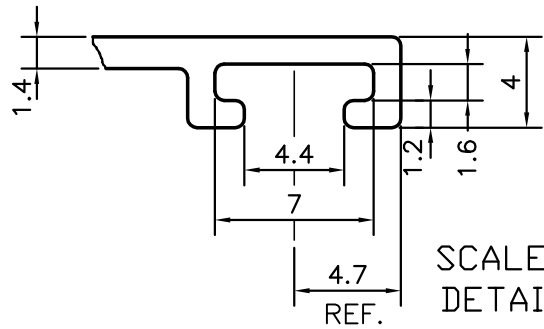

SCALE 3:1  
DETAIL A

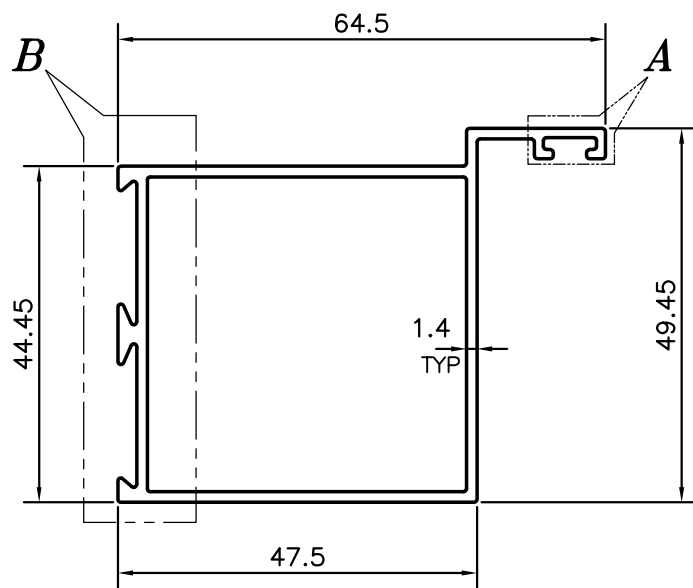

SYMBOL OF QUALITY  
AN ISO 9001 COMPANY

**JINDAL ALUMINIUM LTD.**  
BANGALORE-560073 (INDIA)

	NAME	DATE
DRAWN	J.P.KAUSHIK	13-08-2011
CHECKED		
APPROVED	S.S.GARG	26-08-2011
SCALE		1:1
AREA	mm <sup>2</sup>	307.505
PERIMETER	mm.	261.728
WEIGHT	kg/m	0.830
DRAWING No.	SECTION No.	
P-11166	-	
19613	19613	

1. ALL DIMENSIONS ARE IN mm.
2. ROUND OFF ALL SHARP CORNERS WITH 0.40 mm.
3. TOLERANCES WILL BE AS PER,BS:EN-755-9 UNLESS OTHERWISE SPECIFIED

PARTY'S NAME	PRAYOSHA ENTERPRISES LTD., UGANDA
PARTY'S DRAWING No.	LIGHTER OF SECTION No.19565
ALLOY & TEMPER	6063 T6
DESCRIPTION	ARCHITECHTURAL SECTION