

P-11332-1

19614

EXPOSED SURFACE  
BETTER FINISH REQUIRED

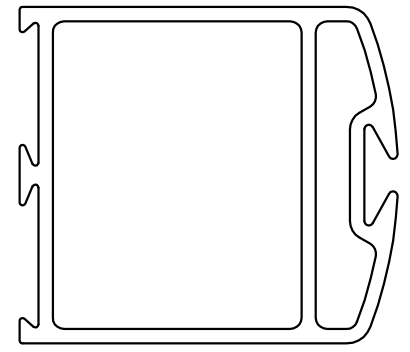

SCALE:- 1:1

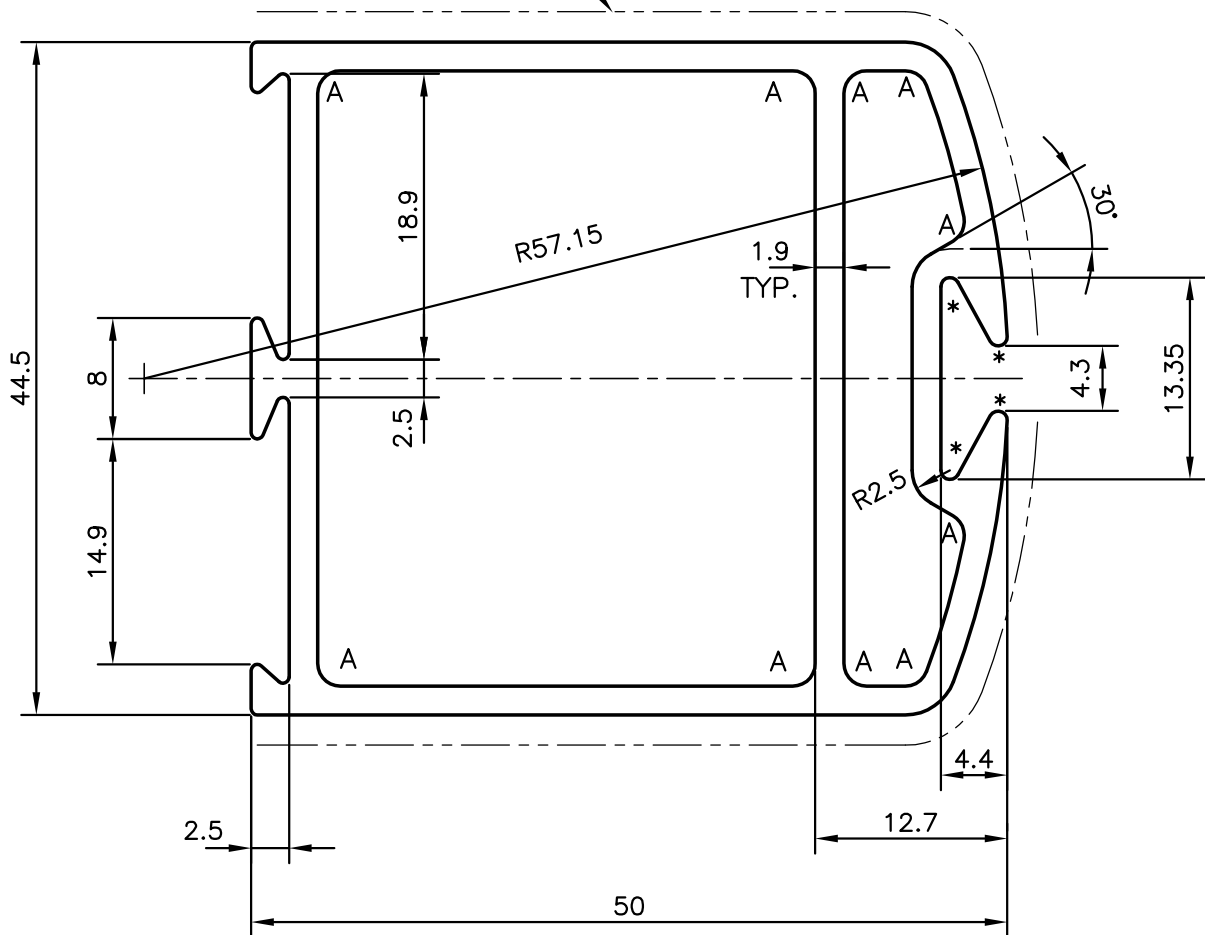

A = RADIUS 1.5 mm. ( 10 PLACES)  
\* = RADIUS 0.6 mm. ( 4 PLACES)



SYMBOL OF QUALITY  
AN ISO 9001 COMPANY

**JINDAL ALUMINIUM LTD.**  
BANGALORE-560073 (INDIA)

	NAME	DATE
DRAWN	PARVESH	29-11-2011
CHECKED		
APPROVED	S.S.GARG	23-12-2011
SCALE		2:1
AREA mm <sup>2</sup>		460.476
PERIMETER mm.		222.673
WEIGHT kg/m		1.243
DRAWING No.	SECTION No.	
P-11332-1	-	
19614	19614	

1. ALL DIMENSIONS ARE IN mm.
2. ROUND OFF ALL SHARP CORNERS WITH 0.40 mm.
3. TOLERANCES WILL BE AS PER, IS:6477-1983 UNLESS OTHERWISE SPECIFIED

PARTY'S NAME	GENERAL CATEGORY, CHENNAI MARKET
PARTY'S DRAWING No.	AS PER DRAWING
ALLOY & TEMPER	HE9 WP
DESCRIPTION	DOOR VERTICAL SECTION