

P-11555

S3181

19616

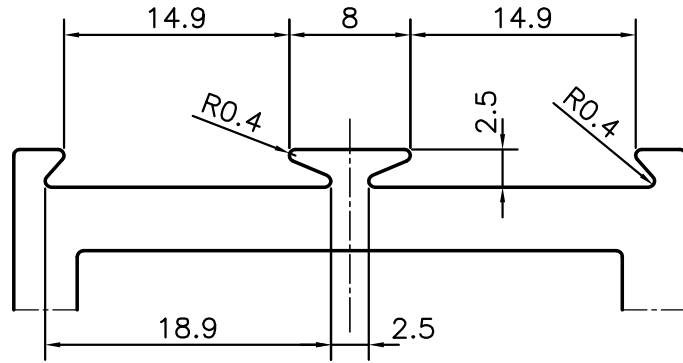

DETAIL OF "A"
SCALE 2:1

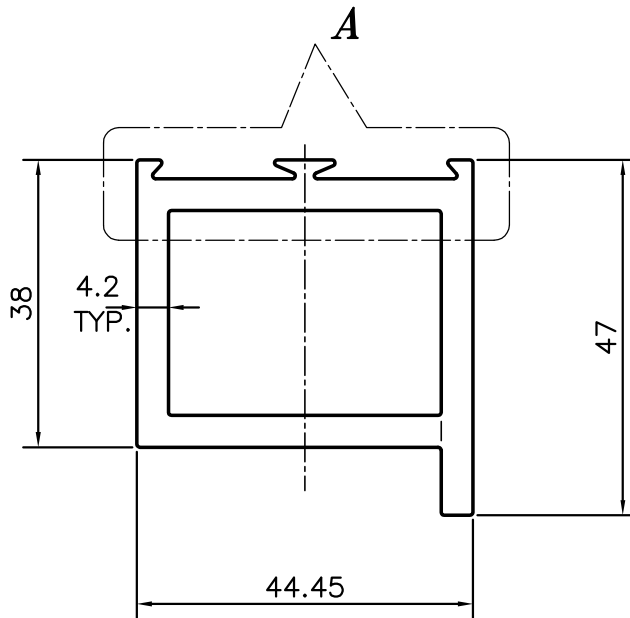

SYMBOL OF QUALITY
AN ISO 9001 COMPANY

JINDAL ALUMINIUM LTD.
BANGALORE-560073 (INDIA)

	NAME	DATE
DRAWN	PARVESH	08-02-2012
CHECKED		
APPROVED	B.NATARAJ	10-02-2012
SCALE		1:1
AREA mm ²		665.445
PERIMETER mm.		202.788
WEIGHT kg/m		1.797
DRAWING No.	SECTION No.	
P-11555	-	
S3181	S3181	
19616	19616	

1. ALL DIMENSIONS ARE IN mm.
2. ROUND OFF ALL SHARP CORNERS WITH 0.40 mm.
3. TOLERANCES WILL BE AS PER IS:6477-1983, UNLESS OTHERWISE SPECIFIED

PARTY'S NAME	ASIAN CONSTRUCTION CO., BHOPAL
PARTY'S DRAWING No.	HEAVIER OF SECTION NO. 19566
ALLOY & TEMPER	6063 T6
DESCRIPTION	ARCHITECTURAL SECTION