

P-11032

S2994

19617

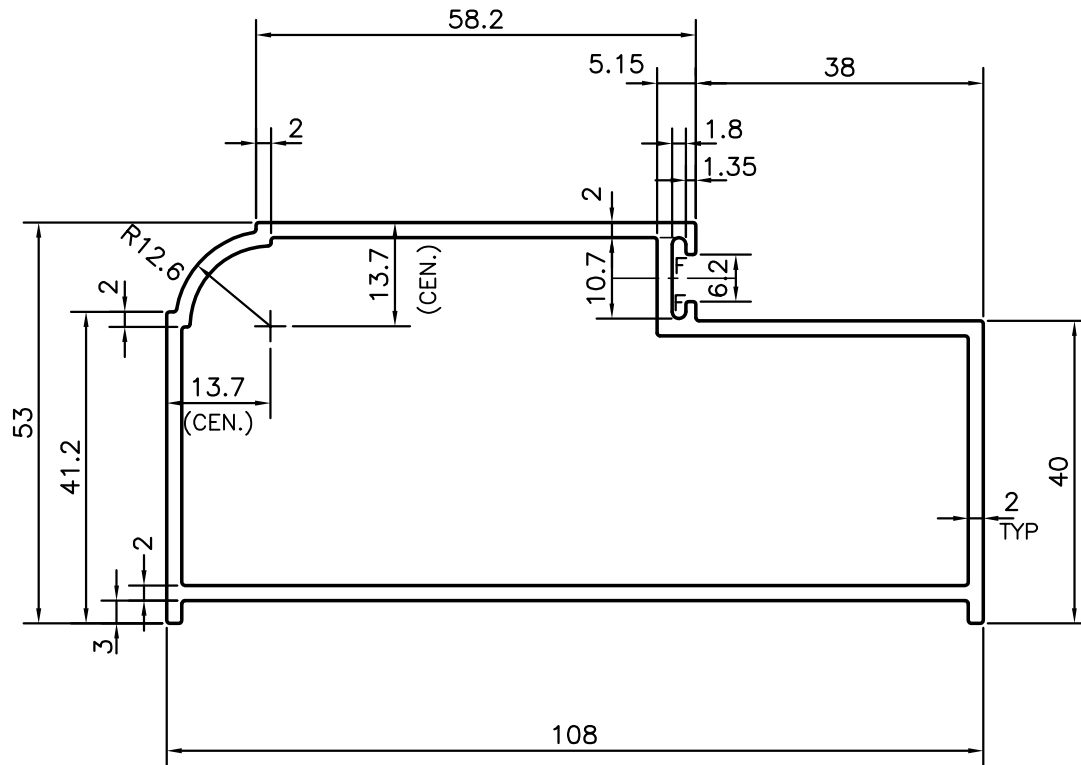

F = FULL RADIUS (2 PLACES)



SYMBOL OF QUALITY
AN ISO 9001 COMPANY

JINDAL ALUMINIUM LTD.
BANGALORE-560073 (INDIA)

	NAME	DATE
DRAWN	J.P.KAUSHIK	17-06-2011
CHECKED		
APPROVED	S.S.GARG	08-07-2011
SCALE		1:1
AREA mm ²		632.082
PERIMETER mm.		333.814
WEIGHT kg/m		1.707
DRAWING No.	SECTION No.	
P-11032	-	
S2994	S2994	
19617	19617	

1. ALL DIMENSIONS ARE IN mm.
2. ROUND OFF ALL SHARP CORNERS WITH 0.40 mm.
3. TOLERANCES WILL BE AS PER, IS:6477-1983 UNLESS OTHERWISE SPECIFIED

PARTY'S NAME GLAZE TECNO INDIA., MUMBAI

PARTY'S DRAWING No. SP-4343

ALLOY & TEMPER 6063 T6

DESCRIPTION DOOR FRAME SECTION