

P-11642

19618

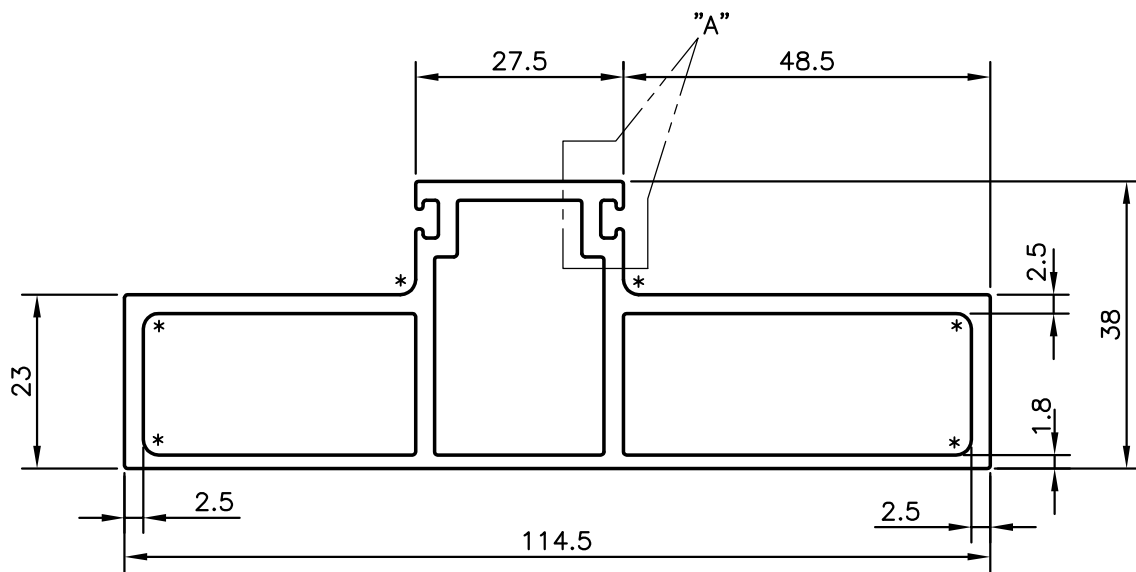

* = RADIUS 2 (6 PLACES)

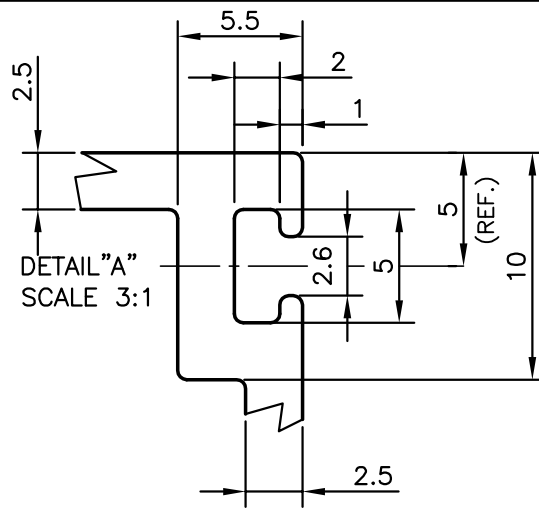

SYMBOL OF QUALITY
AN ISO 9001 COMPANY

JINDAL ALUMINIUM LTD.
BANGALORE-560073 (INDIA)

	NAME	DATE
DRAWN	J.P.KAUSHIK	06-04-2012
CHECKED		
APPROVED	S.S.GARG	09-06-2012
SCALE		1:1
AREA mm ²		781.989
PERIMETER mm.		321.106
WEIGHT kg/m		2.111
DRAWING No.	SECTION No.	
P-11642	-	
19618	19618	

1. ALL DIMENSIONS ARE IN mm.
2. ROUND OFF ALL SHARP CORNERS WITH 0.40 mm.
3. TOLERANCES WILL BE AS PER IS:6477-1983 UNLESS OTHERWISE SPECIFIED

PARTY'S NAME	GENERAL CATEGORY, DELHI MARKET
PARTY'S DRAWING No.	BM-20-182
ALLOY & TEMPER	HE9 WP
DESCRIPTION	DOOR FRAME DOUBLE REBATE