

P-12492

S3638

19626

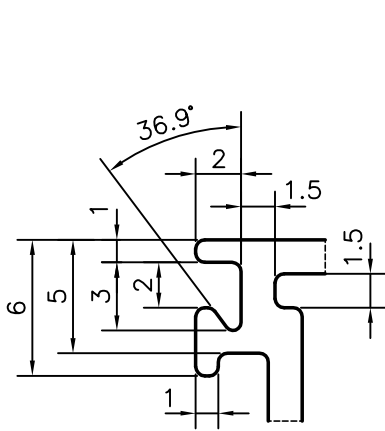
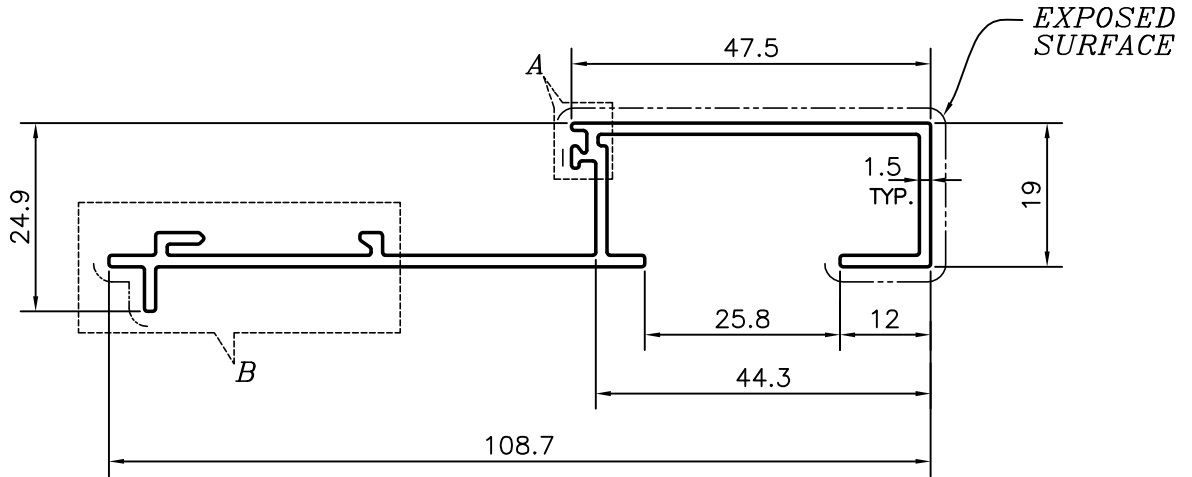
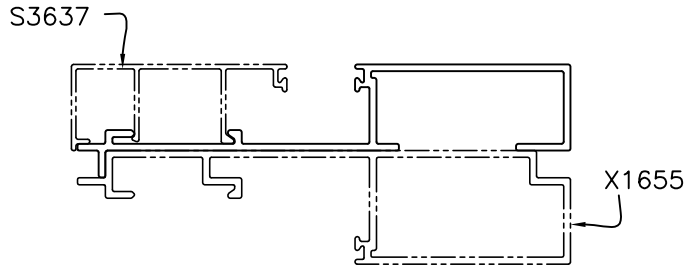

DETAIL OF "A"  
SCALE 3:1

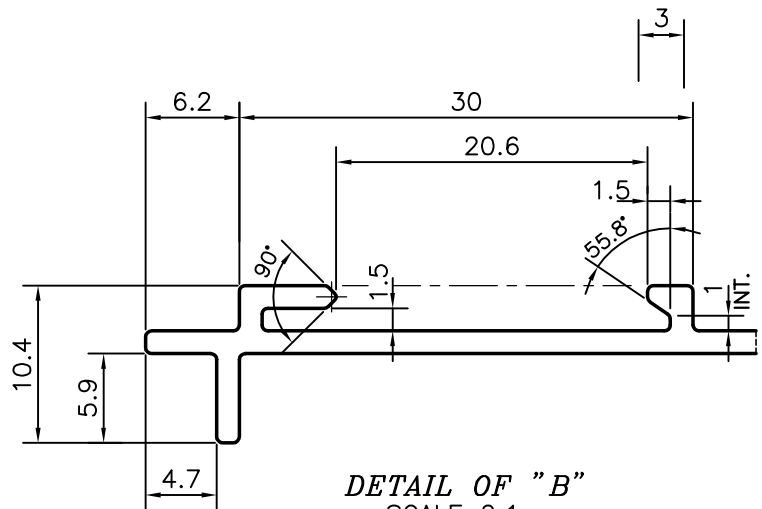

DETAIL OF "B"  
SCALE 2:1



SYMBOL OF QUALITY  
AN ISO 9001 COMPANY

**JINDAL ALUMINIUM LTD.**  
BANGALORE-560073 (INDIA)

	NAME	DATE
DRAWN	PARVESH	31-01-2013
CHECKED		
APPROVED	S.S.GARG	07-02-2013
SCALE		1:1
AREA mm <sup>2</sup>		276.055
PERIMETER mm.		366.519
WEIGHT kg/m		0.745
DRAWING No.	SECTION No.	
P-12492	-	
S3638	S3638	
19626	19626	

1. ALL DIMENSIONS ARE IN mm.
2. ROUND OFF ALL SHARP CORNERS WITH 0.40 mm.
3. TOLERANCES WILL BE AS PER IS:3965-1981 , UNLESS OTHERWISE SPECIFIED

PARTY'S NAME	SOUNDARYA DECORATORS PVT. LTD., CHENNAI
PARTY'S DRAWING No.	AS PER Auto CAD DRAWING-110-V2
ALLOY & TEMPER	HE9 WP
DESCRIPTION	DOOR PARTITION SECTION