

P-12536  
S3665  
19631

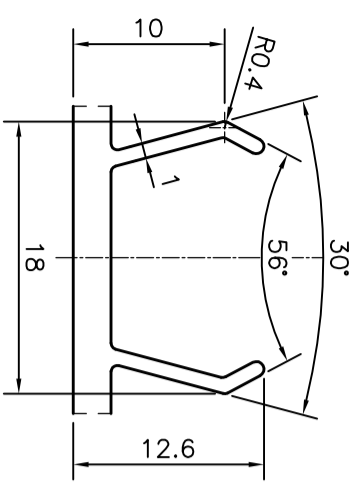

DETAIL OF "A"  
SCALE 2:1

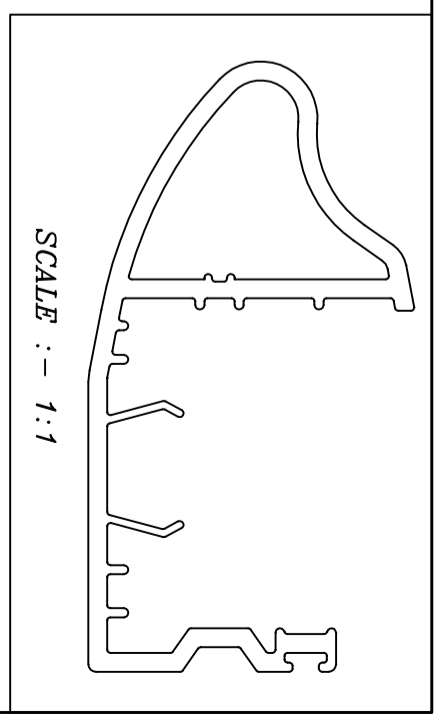
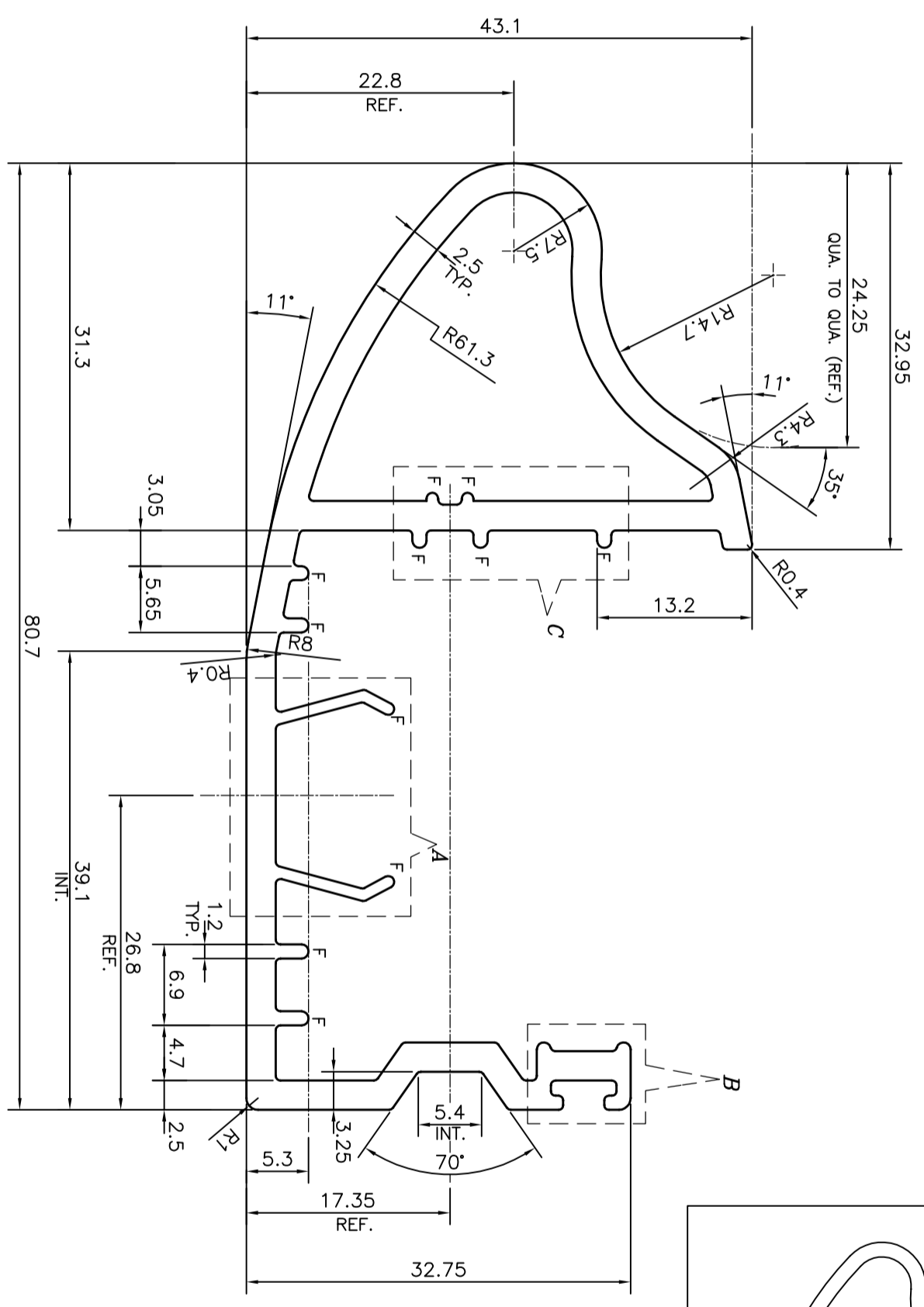
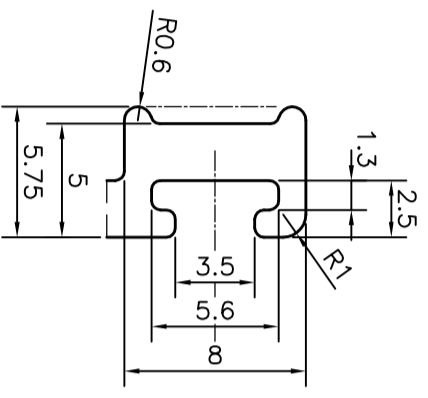

DETAIL OF "B"  
SCALE 3:1

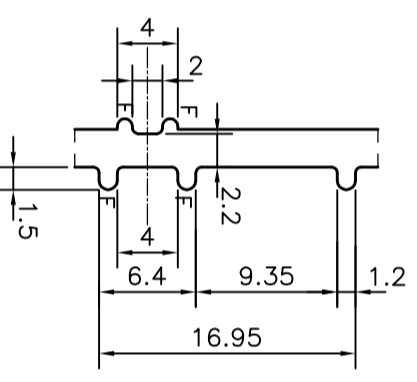

DETAIL OF "C"  
SCALE 3:1

F = FULL RADIUS (11 PLACES)

 <b>JINDAL ALUMINIUM LTD.</b> BANGALORE-560073 (INDIA)		DRAWN	NAME	DATE
		CHECKED	PARVESH	14-02-2013
1. ALL DIMENSIONS ARE IN mm. 2. ROUND OFF ALL SHARP CORNERS WITH 0.40 mm. 3. TOLERANCES WILL BE AS PER IS:6477-1983, UNLESS OTHERWISE SPECIFIED		APPROVED	S.S.GARG	20-02-2013
PARTY'S NAME TORFENSTER SYSTEMS (INDIA) PVT. LTD., BANGALORE		SCALE	2:1	
PARTY'S DRAWING No. AS PER Auto CAD DRAWING		AREA	537.073	
ALLOY & TEMPER HE9 WP		PERIMETER	365.094	
DESCRIPTION DOOR PARTITION SECTION		WEIGHT kg/m	1.45	
		DRAWING No.	SECTION No.	
		P-12536	-	
		S3665	S3665	
		19631	19631	