

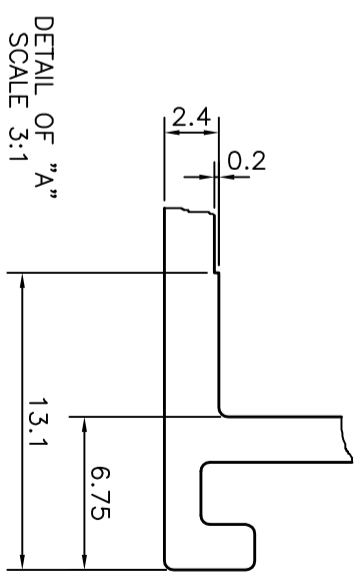

P-11182-2  
X1555  
19632

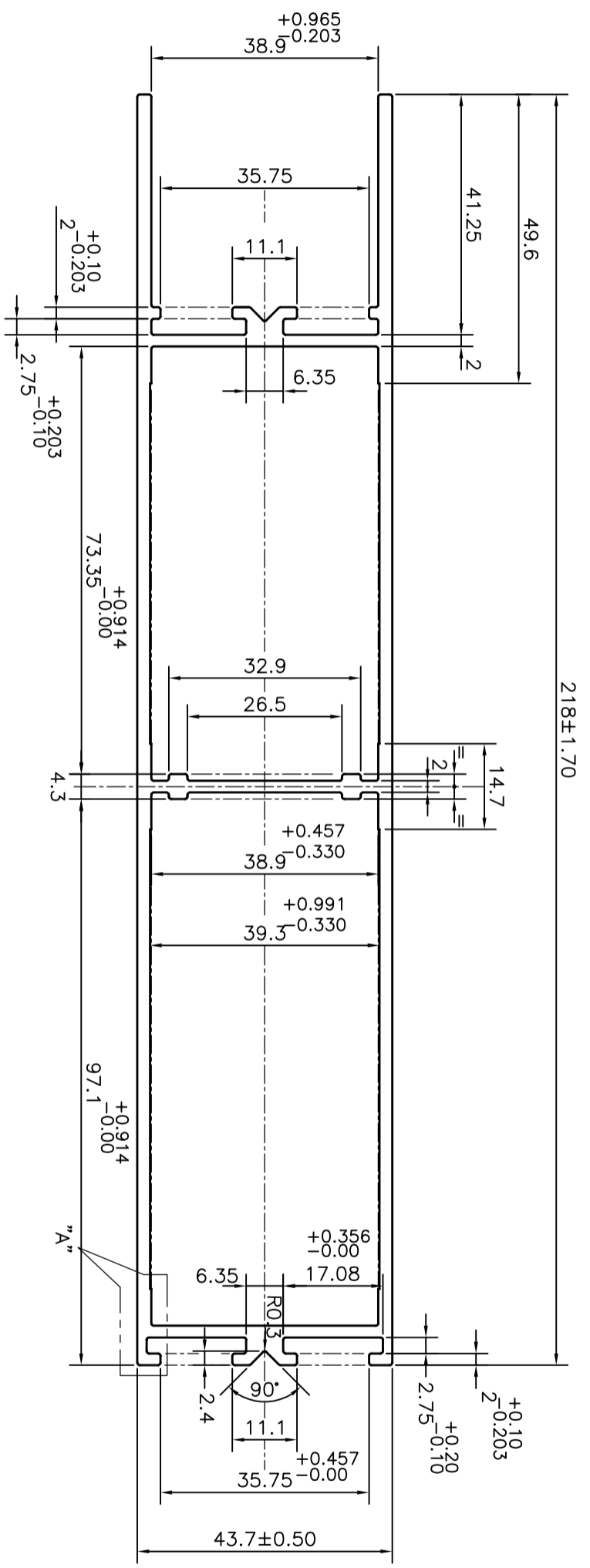

DETAIL OF "A"  
SCALE 3:1

 <b>JINDAL</b> SYMBOL OF QUALITY AN ISO 9001 COMPANY		<b>JINDAL ALUMINIUM LTD.</b> BANGALORE-560073 (INDIA)		DRAWN J.P. KAUSHIK 26-09-2011	NAME DATE
1. ALL DIMENSIONS ARE IN mm. 2. ROUND OFF ALL SHARP CORNERS WITH 0.40 mm. 3. TOLERANCES WILL BE AS PER BS:EN-755-9 UNLESS OTHERWISE SPECIFIED		APPROVED S.S.GARG 22-10-2011	CHECKED   	SCALE 1:1	AREA mm <sup>2</sup> 1313.223
PARTY'S NAME DORMA INDIA PVT. LTD., CHENNAI	PARTY'S DRAWING No. AS PER DRAWING	WEIGHT kg/m 3.546	PERIMETER mm. 666.189	DRAWING No. P-11182-2	SECTION No. -
ALLOY & TEMPER 6063 T6	DESCRIPTION ESA BOTTOM RAIL	DRAWING No. X1555	SECTION No. 19632	DRAWING No. X1555	SECTION No. 19632