

P-13783

19635

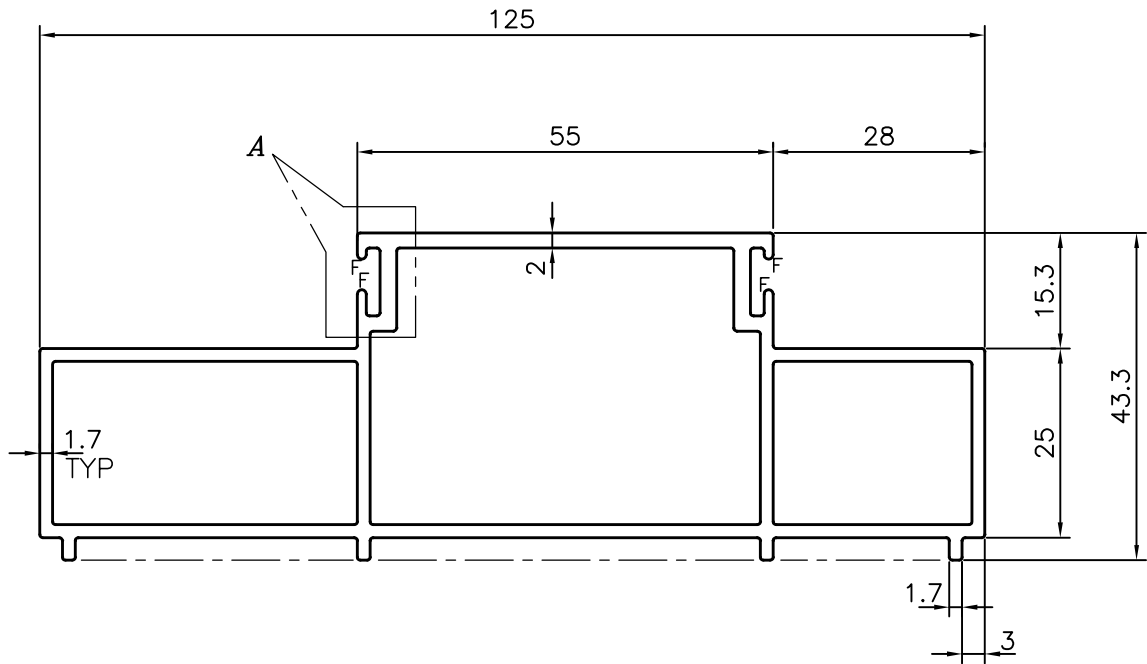

F= FULL RADIUS (4 PLACES)

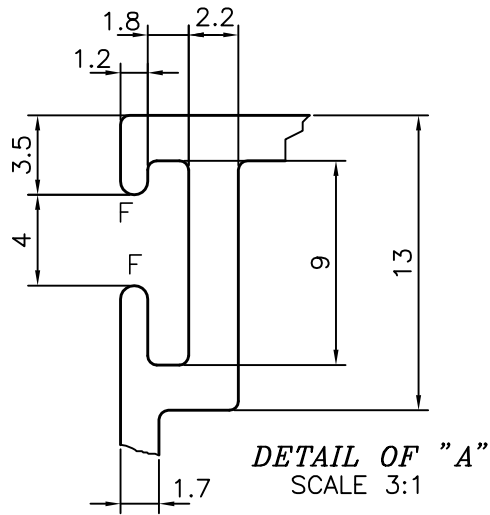

SYMBOL OF QUALITY  
AN ISO 9001 COMPANY

**JINDAL ALUMINIUM LTD.**  
BANGALORE-560073 (INDIA)

	NAME	DATE
DRAWN	J.P.KAUSHIK	25-07-2014
CHECKED		
APPROVED	S.S.GARG	13-08-2014
SCALE		1:1
AREA	mm <sup>2</sup>	694.711
PERIMETER	mm.	379.046
WEIGHT	kg/m	1.876
DRAWING No.	SECTION No.	
P-13783	-	
19635	19635	

1. ALL DIMENSIONS ARE IN mm.
2. ROUND OFF ALL SHARP CORNERS WITH 0.4 mm.
3. TOLERANCES WILL BE AS PER IS:6477-1983, UNLESS OTHERWISE SPECIFIED

PARTY'S NAME	GENERAL CATEGORY MUMBAI MARKET
PARTY'S DRAWING No.	AS PER DRAWING
ALLOY & TEMPER	HE9 WP
DESCRIPTION	DOOR SECTION