

P-12488
S3628
19640

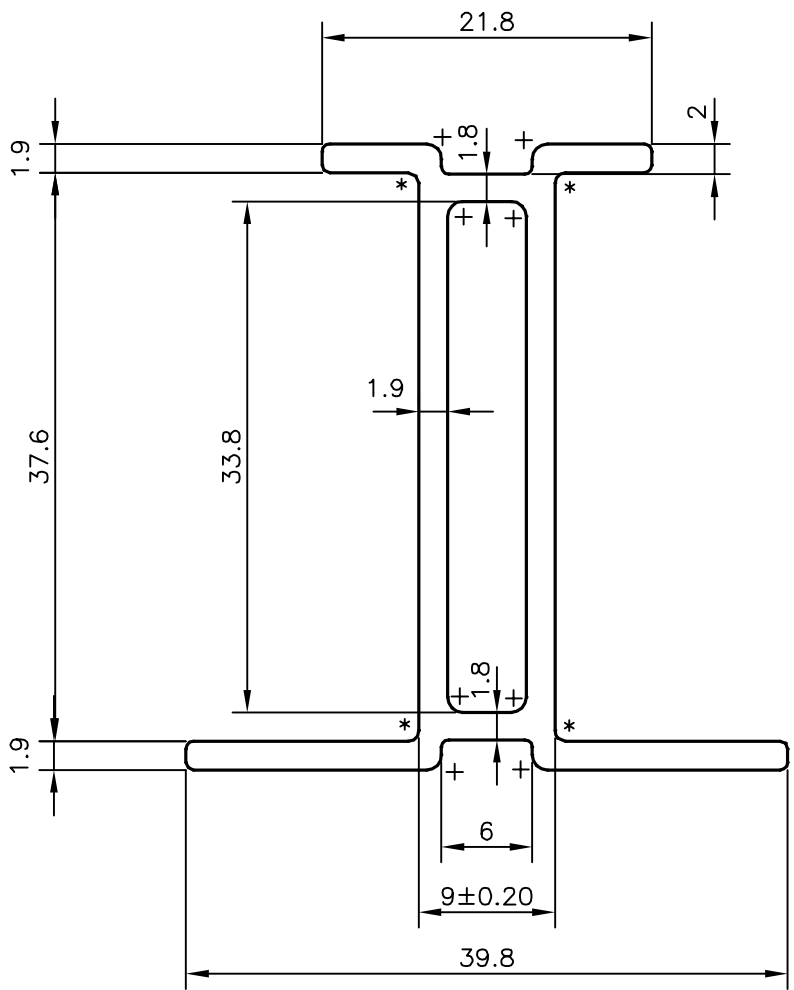

* = 0.70 RADIUS (4)
+ = 1.0 RADIUS (8)
UNSPECIFIED RADII 0.50 mm.

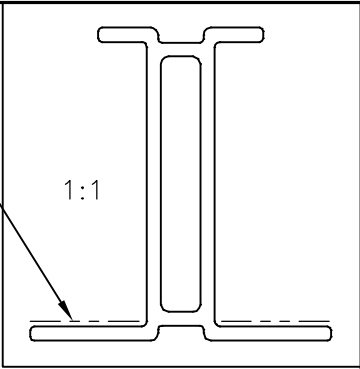

JINDAL ALUMINIUM LTD.
BANGALORE-560073 (INDIA)

	NAME	DATE
DRAWN	J.P.KAUSHIK	30-01-2013
CHECKED		
APPROVED	S.S.GARG	01-02-2013
SCALE		2:1
AREA mm ²		255.886
PERIMETER mm.		190.506
WEIGHT kg/m		0.691
DRAWING No.	SECTION No.	
P-12488	-	
S3628	S3628	
19640	19640	

1. ALL DIMENSIONS ARE IN mm.
2. ROUND OFF ALL SHARP CORNERS WITH 0.50 mm.
3. TOLERANCES WILL BE AS PER IS:6477-1983 UNLESS OTHERWISE SPECIFIED

PARTY'S NAME	DAN PAL (INDIA) PVT. LTD., NEW DELHI
PARTY'S DRAWING No.	DPI/SPA-22/01/R-0
ALLOY & TEMPER	6063 T5
DESCRIPTION	ALUMINIUM SPACER-22 mm