

P-13348

S4050

19653

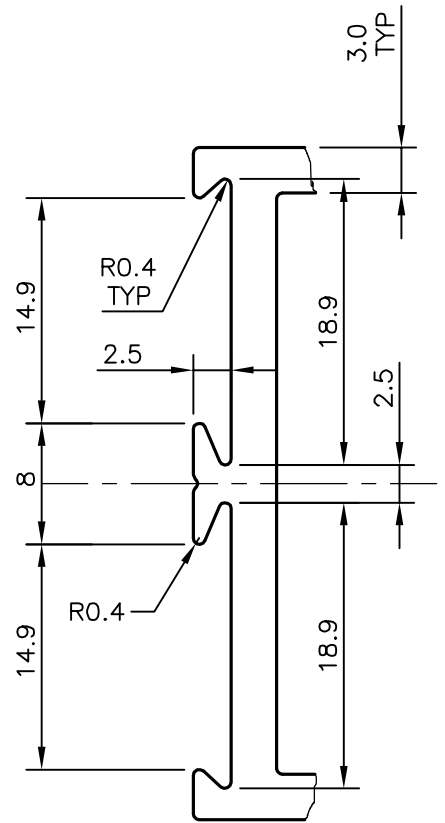

SCALE 2:1  
DETAIL A

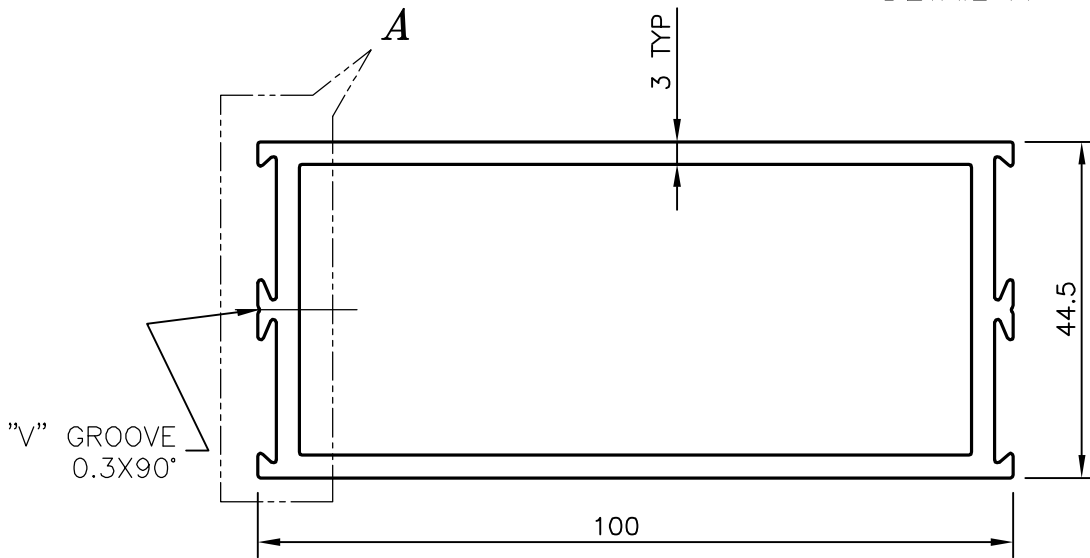

GENERAL WALL THICKNESS:-3.0 mm



SYMBOL OF QUALITY  
AN ISO 9001 COMPANY

**JINDAL ALUMINIUM LTD.**  
BANGALORE-560073 (INDIA)

	NAME	DATE
DRAWN	J.P.KAUSHIK	18-01-2014
CHECKED		
APPROVED	S.S.GARG	01-03-2014
SCALE		1:1
AREA mm <sup>2</sup>		852.615
PERIMETER mm.		330.425
WEIGHT kg/m		2.302
DRAWING No.	SECTION No.	
P-13348	-	
S4050	S4050	
19653	19653	

1. ALL DIMENSIONS ARE IN mm.
2. ROUND OFF ALL SHARP CORNERS WITH 0.40 mm.
3. TOLERANCES WILL BE AS PER IS:6477-1983, UNLESS OTHERWISE SPECIFIED

PARTY'S NAME	AJIT INDIA MADRAS PVT. LTD., CHENNAI
PARTY'S DRAWING No.	HEAVIER OF SECTION No:-19564
ALLOY & TEMPER	HE9 WP
DESCRIPTION	DOOR SECTION