

P-15826

19654

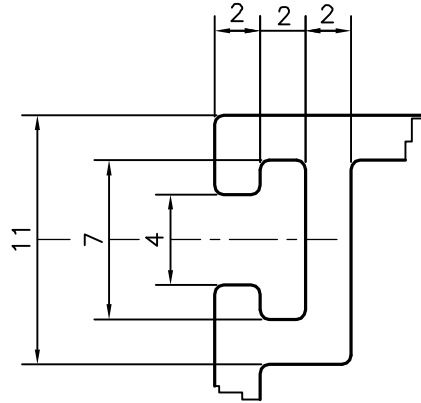

DETAIL OF "A"  
SCALE 3:1

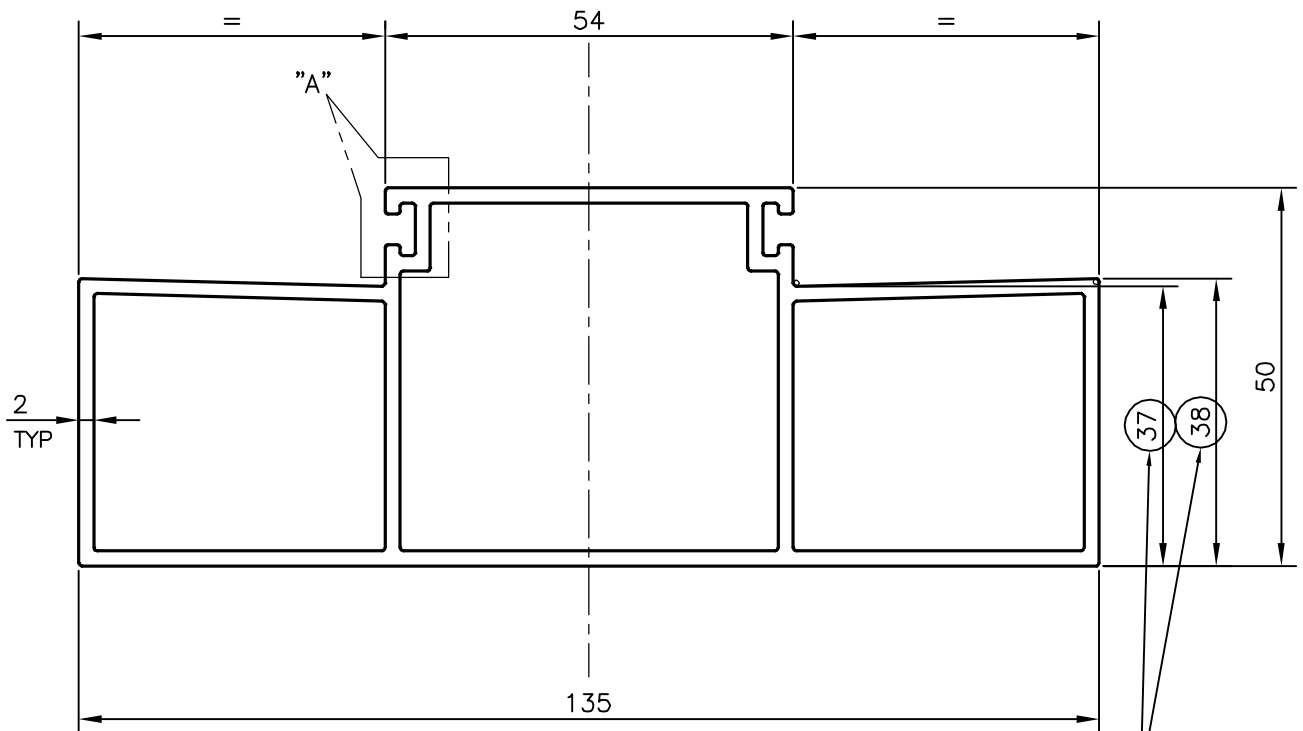

1 mm TAPER

PRODUCTION /QC PLEASE TAKE CARE



SYMBOL OF QUALITY  
AN ISO 9001 COMPANY

**JINDAL ALUMINIUM LTD.**  
BANGALORE-560073 (INDIA)

	NAME	DATE
DRAWN	J.P.KAUSHIK	04-05-2016
CHECKED		
APPROVED	S.S. GARG	13-05-2016

1. ALL DIMENSIONS ARE IN mm.
2. ROUND OFF ALL SHARP CORNERS WITH 0.40 mm.
3. TOLERANCES WILL BE AS PER IS:6477-1983 UNLESS OTHERWISE SPECIFIED

SCALE	1:1
AREA mm <sup>2</sup>	886.269
PERIMETER mm.	395.905
WEIGHT kg/m	2.393

PARTY'S NAME	GENERAL CATEGORY, DELHI MARKET
ISSUE No.	AS PER DRAWING
ALLOY & TEMPER	HE9 WP
DESCRIPTION	DOOR SECTION

DRAWING No.	SECTION No.
P-15826	-
19654	19654