

P-18036

S5745

19670

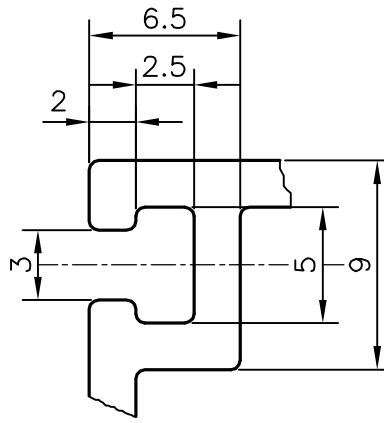

DETAIL OF "A"
SCALE 3:1

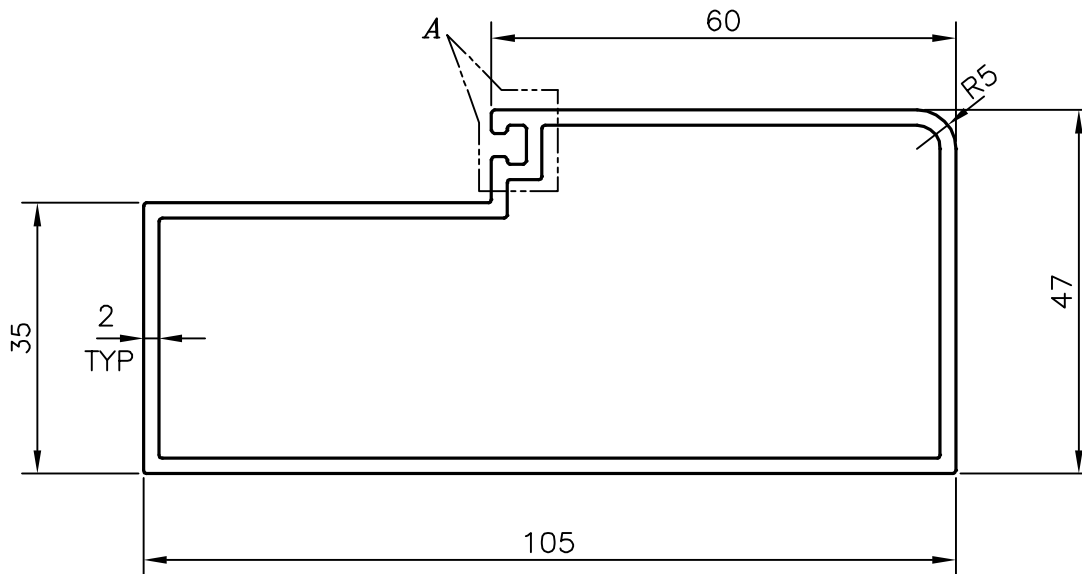

SYMBOL OF QUALITY
AN ISO 9002 COMPANY

JINDAL ALUMINIUM LTD.
BANGALORE-560073 (INDIA)

	NAME	DATE
DRAWN	J.P.KAUSHIK	24-03-2018
CHECKED		
APPROVED	B.NATARAJA	28-03-2018

1. ALL DIMENSIONS ARE IN mm.
2. ROUND OFF ALL SHARP CORNERS WITH 0.40 mm.
3. TOLERANCES WILL BE AS PER IS:6477-1983 , UNLESS OTHERWISE SPECIFIED

SCALE	1:1
AREA mm ²	601.566
PERIMETER mm.	312.622
WEIGHT kg/m	1.624

PARTY'S NAME	POSITIVE DESIGNS, NEW DELHI
PARTY'S DRAWING No.	AS PER DRAWING
ALLOY & TEMPER	6063 T6
DESCRIPTION	DOOR SECTION

DRAWING No.	SECTION No.
P-18036	-
S5745	S5745
19670	19670