

4613

11096

20007

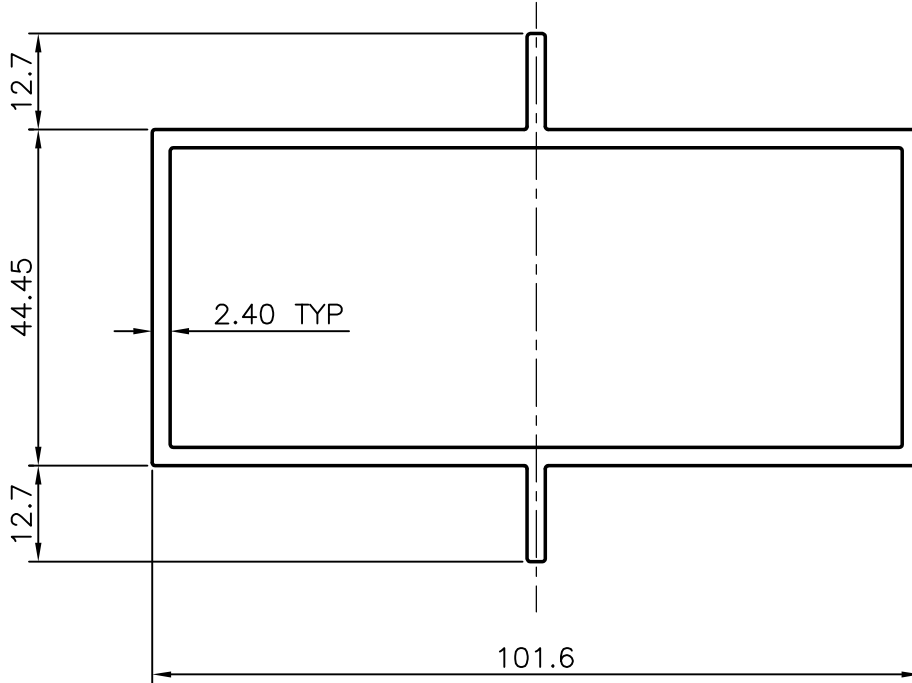

GENERAL WALL THICKNESS = 2.40 mm



SYMBOL OF QUALITY
AN ISO 9001 COMPANY

JINDAL ALUMINIUM LTD.
BANGALORE-560073 (INDIA)

	NAME	DATE
DRAWN	MALINGAPPA	03-11-2003
CHECKED		
APPROVED		
SCALE		1:1
AREA mm ²		739
PERIMETER mm.		342.9
WEIGHT kg/m		1.995
DRAWING No.		SECTION No.
4613		4613
11096		11096
20007		20007

1. ALL DIMENSIONS ARE IN mm.
2. ROUND OFF ALL SHARP CORNERS WITH 0.40 mm.
3. TOLERANCES WILL BE AS PER IS: 6477-1983 UNLESS OTHERWISE SPECIFIED

PARTY'S NAME	-
PARTY'S DRAWING No.	-
ALLOY & TEMPER	HE9 WP
DESCRIPTION	PARTITION SECTION