

4614

11101

20008

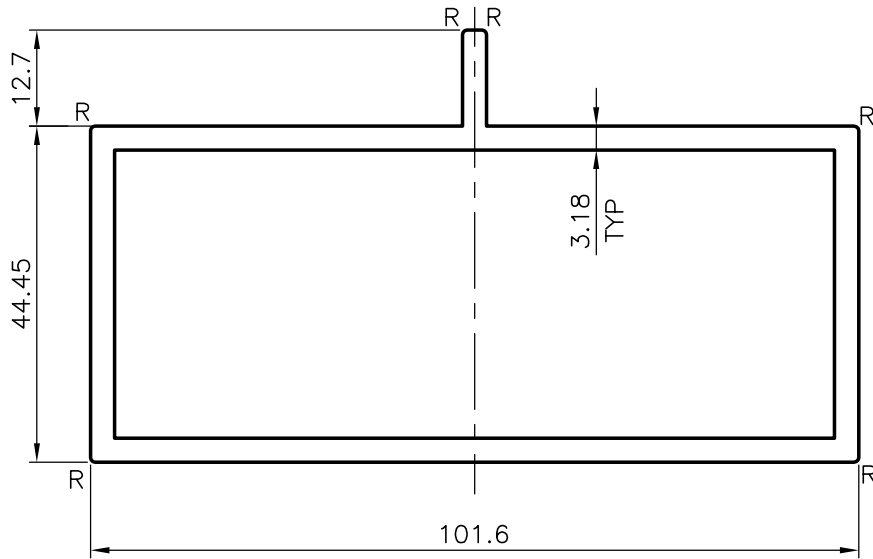

GENERAL WALL THICKNESS = 3.18mm
 R = 0.60mm RADIUS (6 PLACES)



SYMBOL OF QUALITY
 AN ISO 9001 COMPANY

JINDAL ALUMINIUM LTD.
 BANGALORE-560073 (INDIA)

	NAME	DATE
DRAWN	RAGHAVENDRA	30-10-2006
CHECKED		
APPROVED		

1. ALL DIMENSIONS ARE IN mm.
2. ROUND OFF ALL SHARP CORNERS WITH 0.40 mm.
3. TOLERANCES WILL BE AS PER IS:6477-1983 UNLESS OTHERWISE SPECIFIED

SCALE	1:1
AREA mm ²	928.351
PERIMETER mm.	315.955
WEIGHT kg/m	2.508

PARTY'S NAME	-	DRAWING No.	4614	SECTION No.	4614
PARTY'S DRAWING No.	-		11101		11101
ALLOY & TEMPER	HE9 WP		20008		20008
DESCRIPTION	PARTITION SECTION				