

4616

11071

20010

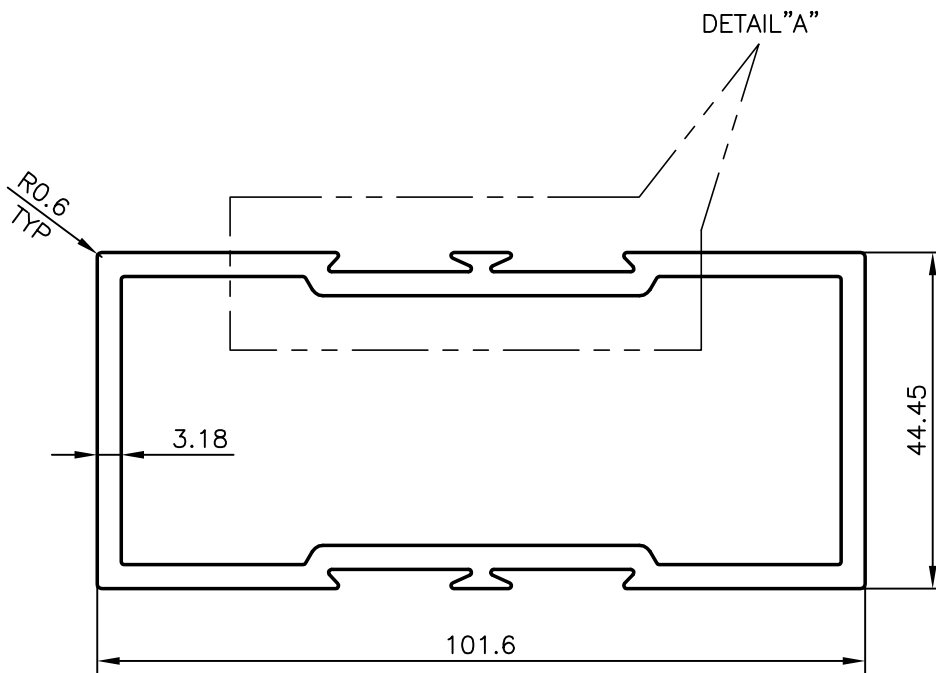
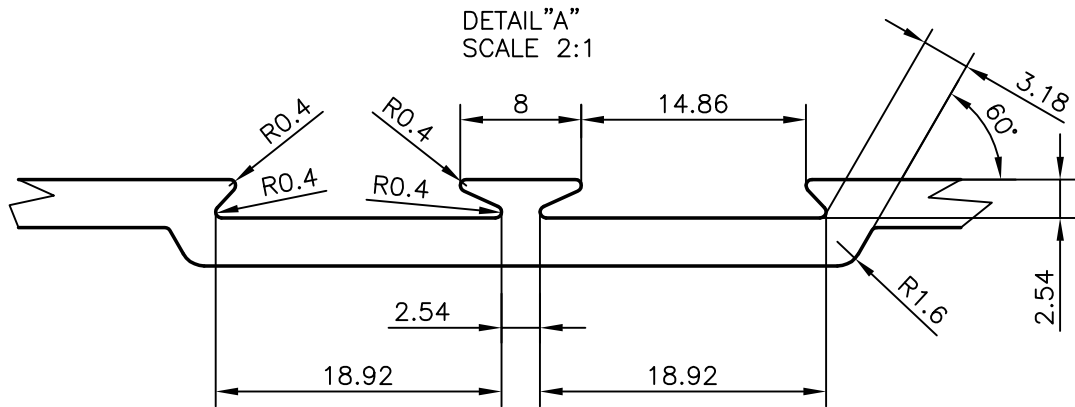

GENERAL WALL THICKNESS :- 3.18 mm.



SYMBOL OF QUALITY  
AN ISO 9001 COMPANY

**JINDAL ALUMINIUM LTD.**  
BANGALORE-560073 (INDIA)

	NAME	DATE
DRAWN	RAGHAVENDRA	23-12-2006
CHECKED		
APPROVED		

1. ALL DIMENSIONS ARE IN mm.
2. ROUND OFF ALL SHARP CORNERS WITH 0.40 mm.
3. TOLERANCES WILL BE AS PER IS:6477-1983 UNLESS OTHERWISE SPECIFIED

SCALE	1:1
AREA mm <sup>2</sup>	993.703
PERIMETER mm.	333.47
WEIGHT kg/m	2.683

PARTY'S NAME	-	DRAWING No.	4616	SECTION No.	4616
PARTY'S DRAWING No.	LIGHTER SECTION OF 4616		11071		11071
ALLOY & TEMPER	HE9 WP		20010		20010
DESCRIPTION	PARTITION SECTION				