

4617

11061

20011

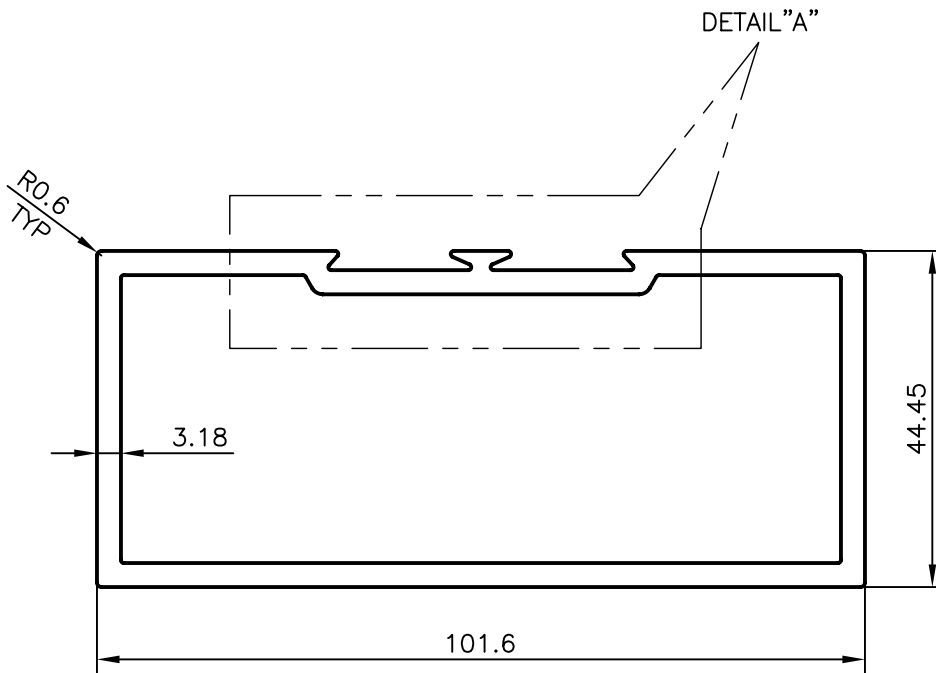
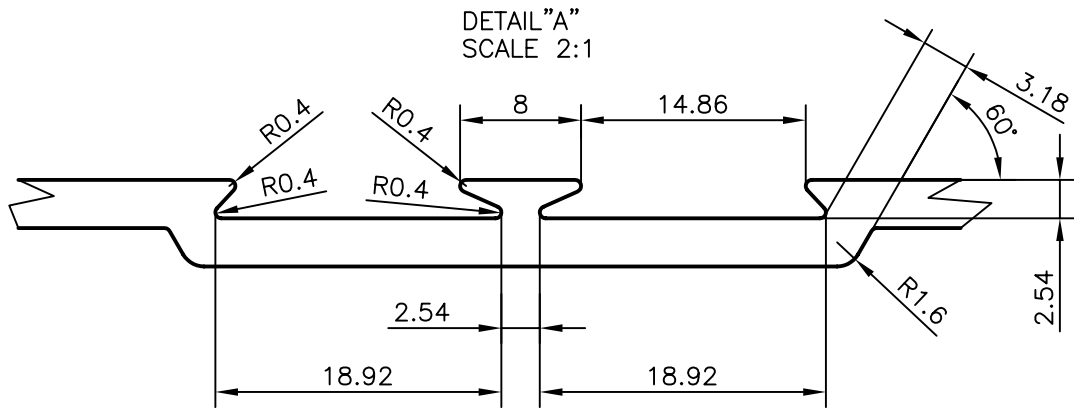

GENERAL WALL THICKNESS :- 3.18 mm.



SYMBOL OF QUALITY
AN ISO 9001 COMPANY

JINDAL ALUMINIUM LTD.
BANGALORE-560073 (INDIA)

| | NAME | DATE |
|----------|-------------|------------|
| DRAWN | RAGHAVENDRA | 23-12-2006 |
| CHECKED | | |
| APPROVED | | |

1. ALL DIMENSIONS ARE IN mm.
2. ROUND OFF ALL SHARP CORNERS WITH 0.40 mm.
3. TOLERANCES WILL BE AS PER IS:6477-1983 UNLESS OTHERWISE SPECIFIED

| | |
|----------------------|---------|
| SCALE | 1:1 |
| AREA mm ² | 941.111 |
| PERIMETER mm. | 312.27 |
| WEIGHT kg/m | 2.541 |

| PARTY'S NAME | | DRAWING No. | SECTION No. |
|---------------------|-------------------|-------------|-------------|
| PARTY'S NAME | - | 4617 | 4617 |
| PARTY'S DRAWING No. | - | 11061 | 11061 |
| ALLOY & TEMPER | HE9 WP | 20011 | 20011 |
| DESCRIPTION | PARTITION SECTION | | |