

4655

11076

20028

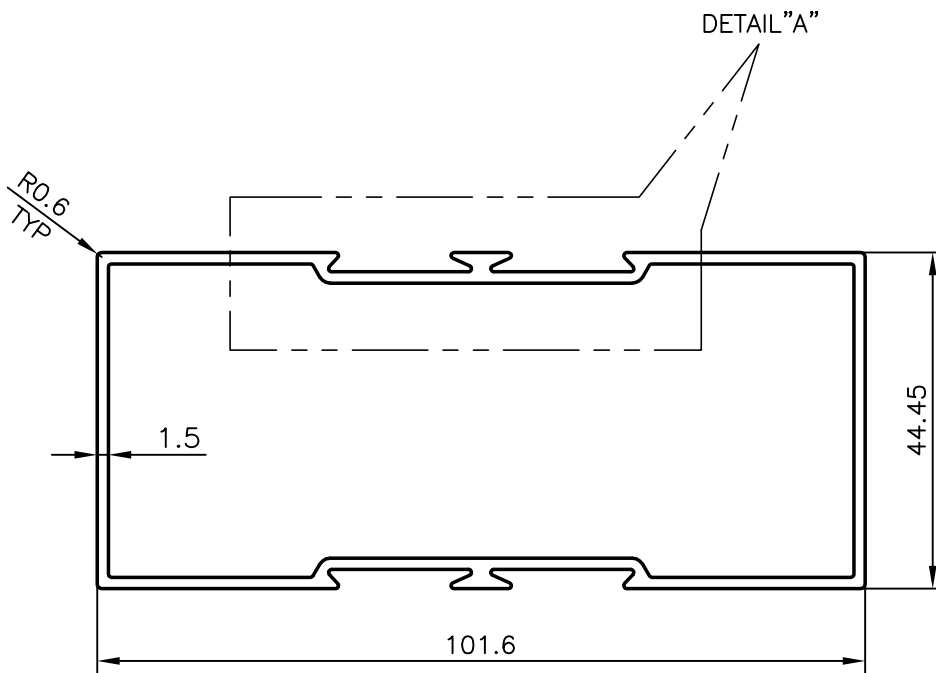
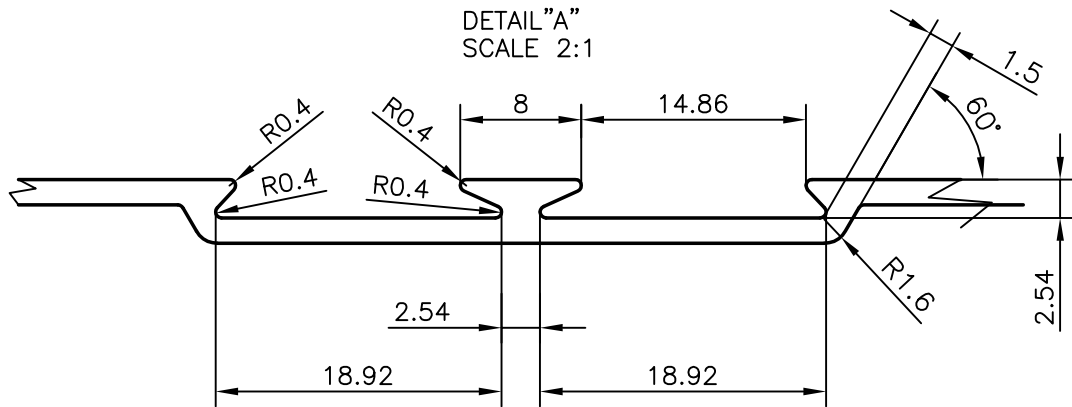

GENERAL WALL THICKNESS :- 1.50 mm.
 NO. OF PIECES IN 100 kgs. :- 21 (AVERAGE)



SYMBOL OF QUALITY
 AN ISO 9001 COMPANY

JINDAL ALUMINIUM LTD.
 BANGALORE-560073 (INDIA)

	NAME	DATE
DRAWN	RAGHAVENDRA	23-12-2006
CHECKED		
APPROVED		

1. ALL DIMENSIONS ARE IN mm.
2. ROUND OFF ALL SHARP CORNERS WITH 0.40 mm.
3. TOLERANCES WILL BE AS PER IS:6477-1983 UNLESS OTHERWISE SPECIFIED

SCALE	1:1
AREA mm ²	481.851
PERIMETER mm.	333.47
WEIGHT kg/m	1.301

PARTY'S NAME		DRAWING No.	SECTION No.
PARTY'S DRAWING No.	LIGHTER SECTION OF 20010	4655	4655
ALLOY & TEMPER	HE9 WP	11076	11076
		20028	20028
DESCRIPTION	PARTITION SECTION		