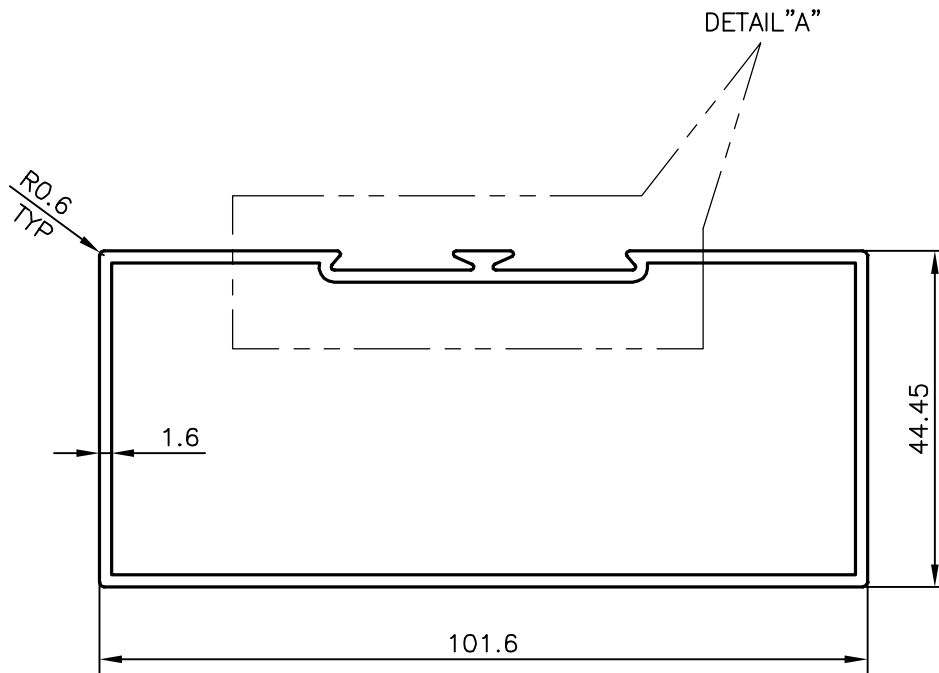
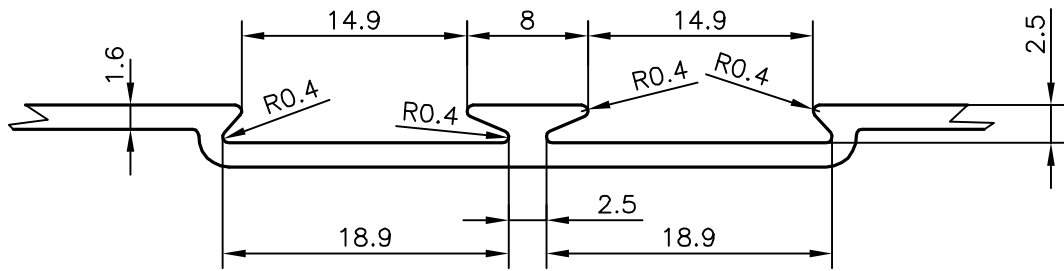

4656

11066

20029

DETAIL "A"  
SCALE 2:1

GENERAL WALL THICKNESS :- 1.60 mm.

NO. OF PIECES IN 100 kgs:- 21 (AVERAGE)

SYMBOL OF QUALITY  
AN ISO 9001 COMPANY**JINDAL ALUMINIUM LTD.**  
BANGALORE-560073 (INDIA)

	NAME	DATE
DRAWN	RAGHAVENDRA	13-09-2006
CHECKED		
APPROVED		

1. ALL DIMENSIONS ARE IN mm.
2. ROUND OFF ALL SHARP CORNERS WITH 0.40 mm.
3. TOLERANCES WILL BE AS PER IS:6477-1983 UNLESS OTHERWISE SPECIFIED

SCALE	1:1
AREA mm <sup>2</sup>	479.323
PERIMETER mm.	311.988
WEIGHT kg/m	1.301

PARTY'S NAME	-	DRAWING No.	4656	SECTION No.	4656
PARTY'S DRAWING No.	-	11066	11066		
ALLOY & TEMPER	HE9 WP	20029	20029		
DESCRIPTION	PARTITION SECTION				