

4657
11003
20030

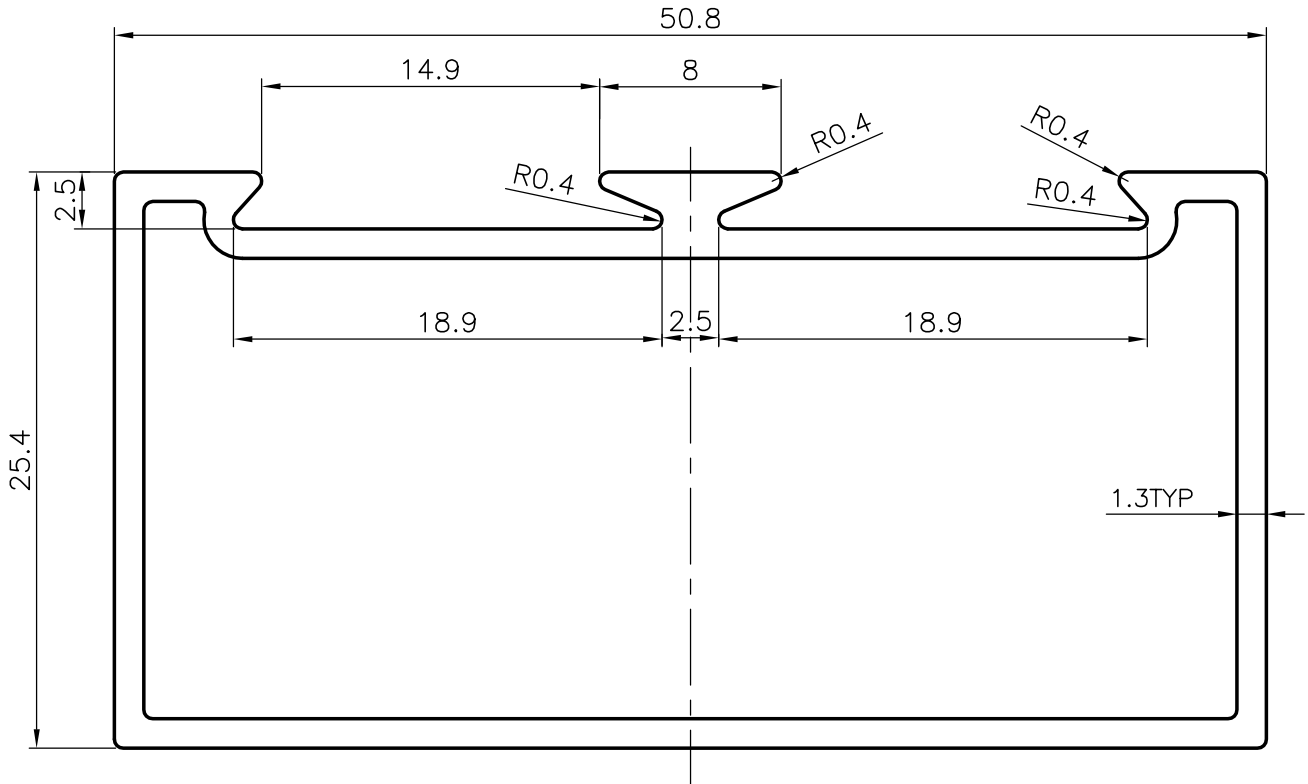
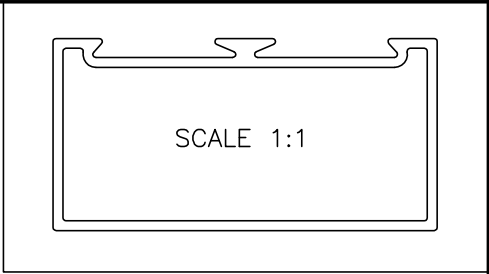

GENERAL WALL THICKNESS = 1.30mm
 NO. OF PIECES IN 100 kgs = 47 (AVERAGE)

<p>SYMBOL OF QUALITY AN ISO 9001 COMPANY</p>	<p>JINDAL ALUMINIUM LTD. BANGALORE-560073 (INDIA)</p>	DRAWN	NAME	DATE
		CHECKED	RAGHAVENDRA	23-12-2006
<p>1. ALL DIMENSIONS ARE IN mm. 2. ROUND OFF ALL SHARP CORNERS WITH 0.40 mm. 3. TOLERANCES WILL BE AS PER IS:6477-1983 UNLESS OTHERWISE SPECIFIED</p>		APPROVED		
		SCALE		3:1
PARTY'S NAME -		AREA mm ²		212.895
		PERIMETER mm.		172.631
PARTY'S DRAWING No. -		WEIGHT kg/m		0.581
		DRAWING No.		SECTION No.
ALLOY & TEMPER HE9 WP		4657		4657
		11003		11003
DESCRIPTION PARTITION SECTION		20030		20030