

4659

11131

20032

*DETAIL "A"*  
*SCALE 2:1*

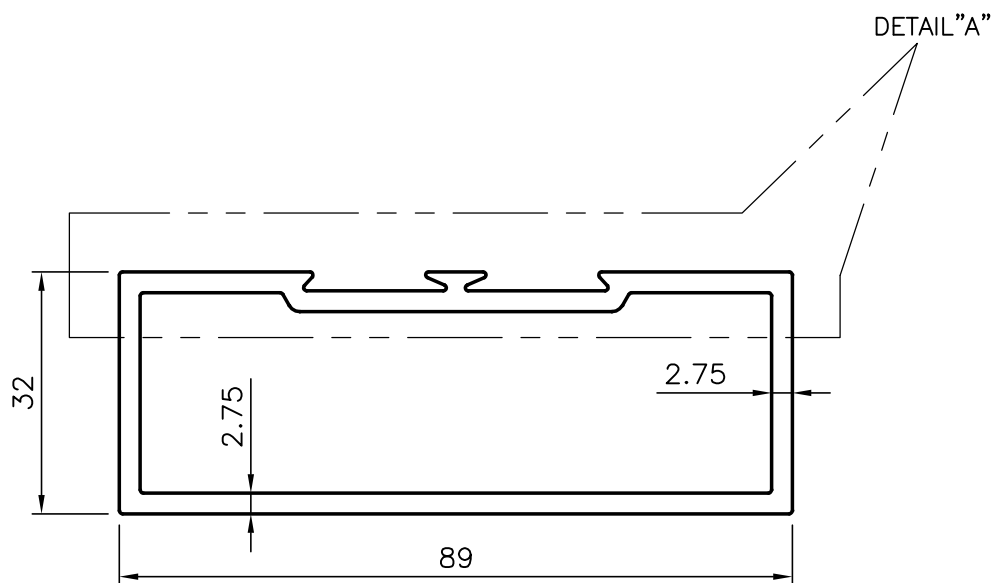
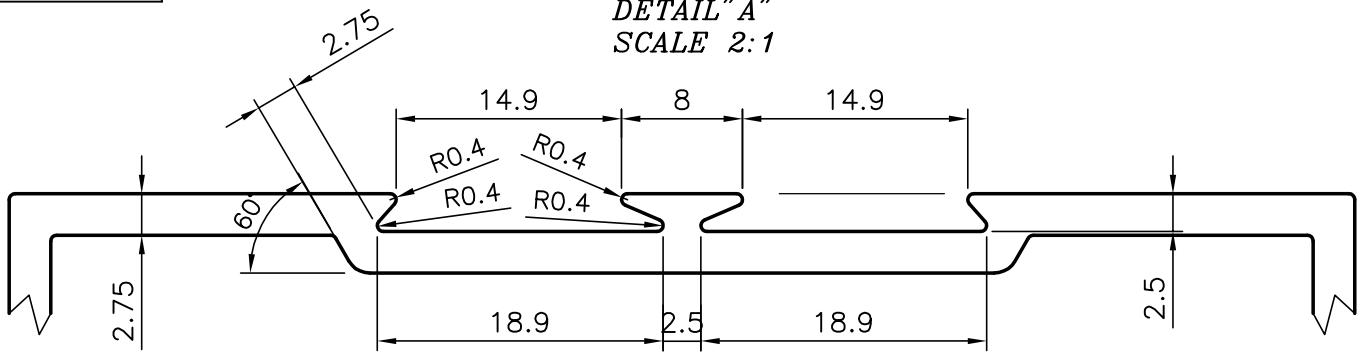

GENERAL WALL THICKNESS = 2.75mm



SYMBOL OF QUALITY  
AN ISO 9002 COMPANY

**JINDAL ALUMINIUM LTD.**  
**BANGALORE-560073 (INDIA)**

|                      | NAME        | DATE       |
|----------------------|-------------|------------|
| DRAWN                | RAGHAVENDRA | 27-07-2006 |
| CHECKED              |             |            |
| APPROVED             |             |            |
| SCALE                |             | 1:1        |
| AREA mm <sup>2</sup> |             | 661.944    |
| PERIMETER mm.        |             | 262.231    |
| WEIGHT kg/m          |             | 1.787      |
| DRAWING No.          | SECTION No. |            |
| 4659                 | 4659        |            |
| 11131                | 11131       |            |
| 20032                | 20032       |            |
|                      |             |            |
|                      |             |            |

1. ALL DIMENSIONS ARE IN mm.
2. ROUND OFF ALL SHARP CORNERS WITH 0.40 mm.
3. TOLERANCES WILL BE AS PER IS:6477-1983 UNLESS OTHERWISE SPECIFIED

|                     |                                   |
|---------------------|-----------------------------------|
| PARTY'S NAME        | METAL BRITES (MADRAS)             |
| PARTY'S DRAWING No. | NIL                               |
| ALLOY & TEMPER      | HE9 WP                            |
| DESCRIPTION         | PARTITION SECTION (SINGLE GROOVE) |