

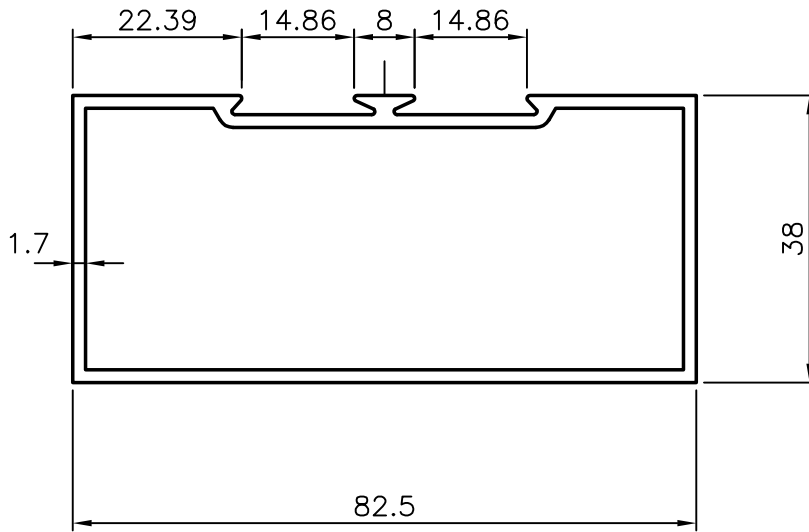

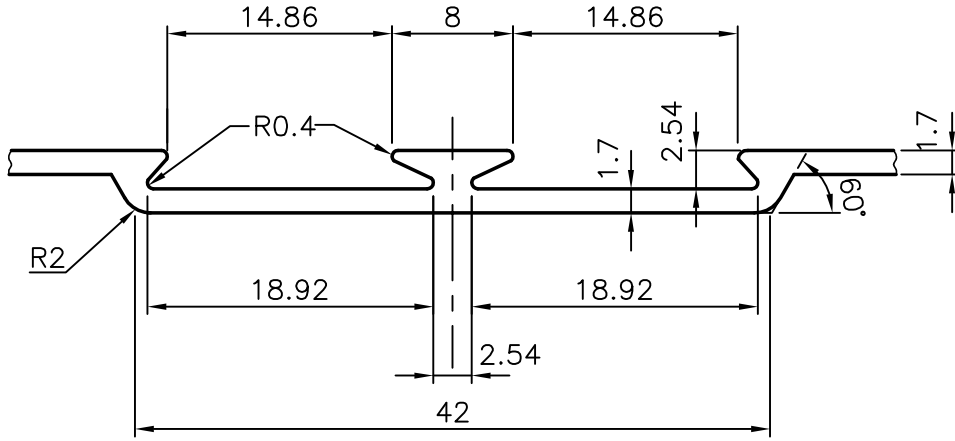

4666
11051
20036



NO. OF PCS. REQD. IN 100 Kgs:- 24 NOS.

 SYMBOL OF QUALITY AN ISO 9002 COMPANY	JINDAL ALUMINIUM LTD. BANGALORE-560073 (INDIA)			NAME	DATE	
				DRAWN	R.D.SHARMA	19-3-90
				CHECKED		
1. ALL DIMENSIONS ARE IN mm 2. ROUND OFF SHARP CORNERS WITH 0.4mm R 3. TOLERANCES WILL BE AS PER IS : 3965-1981				APPROVED		
PARTY'S NAME	-			SCALE	1:1 & 2:1	
PARTY'S DRAWING No.	-	FINISH	-	WEIGHT kg/m	1.139	
ALLOY & TEMPER	HE 9 WP	LENGTH:	3658mm	SECTION No.	 20036	
DESCRIPTION	PARTITION SECTION			DRAWING No.	 20036	