

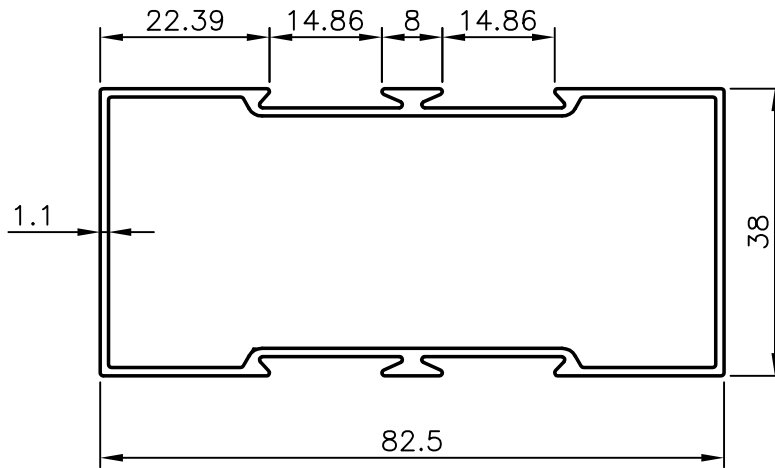

4667
11057
20037

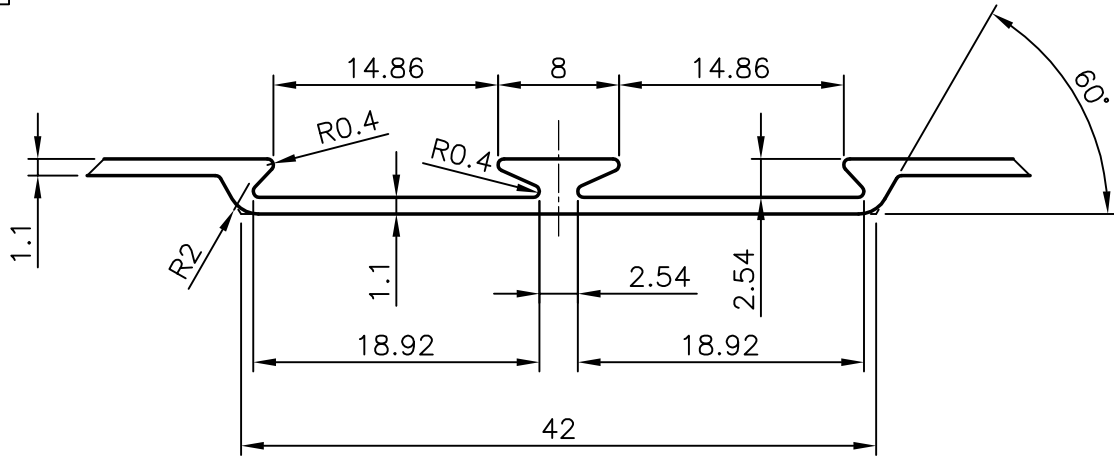

NO. OF PIECES REQUIRED IN 100 kgs :- 33 NOS.

 SYMBOL OF QUALITY AN ISO 9001 COMPANY	JINDAL ALUMINIUM LTD. BANGALORE-560073 (INDIA)	NAME		DATE	
		DRAWN		PRASANNA.H.	10-02-2007
		CHECKED			
APPROVED					
1. ALL DIMENSIONS ARE IN mm. 2. ROUND OFF ALL SHARP CORNERS WITH 0.40 mm. 3. TOLERANCES WILL BE AS PER IS:6477-1983 UNLESS OTHERWISE SPECIFIED		SCALE		1:1	
		AREA mm ²		308.642	
		PERIMETER mm.		282.714	
PARTY'S NAME		WEIGHT kg/m		0.833	
PARTY'S DRAWING No.		DRAWING No.	SECTION No.		
ALLOY & TEMPER		4667	4667		
DESCRIPTION		11057	11057		
PARTITION SECTION		20037	20037		