

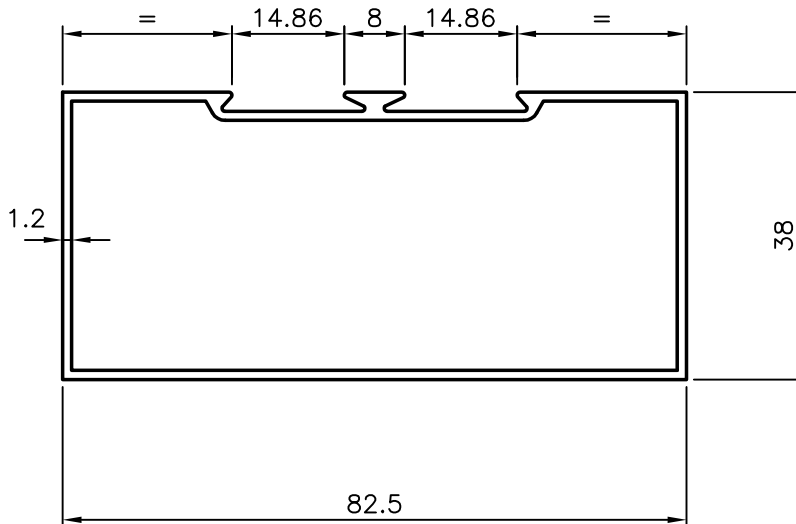

4668
11052
20038

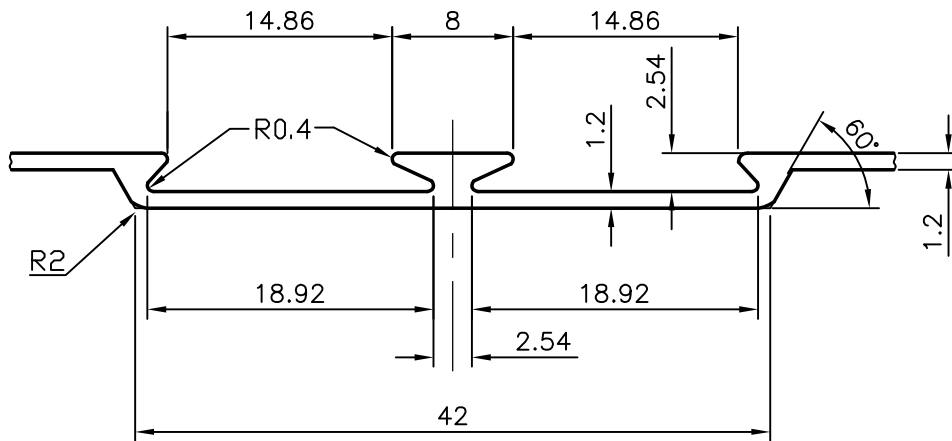

GENERAL WALL THICKNESS 1.20 mm
NO. OF PCS. REQD. IN 100 Kgs:- 33 NOS.

 SYMBOL OF QUALITY AN ISO 9001 COMPANY	JINDAL ALUMINIUM LTD. BANGALORE-560073 (INDIA)	NAME		DATE
		DRAWN	RAGHAVENDRA	30-10-2006
		CHECKED		
1. ALL DIMENSIONS ARE IN mm. 2. ROUND OFF ALL SHARP CORNERS WITH 0.40 mm. 3. TOLERANCES WILL BE AS PER IS:6477-1983 UNLESS OTHERWISE SPECIFIED		SCALE		1:1
PARTY'S NAME		AREA mm ²		307.018
PARTY'S DRAWING No.		PERIMETER mm.		262.187
ALLOY & TEMPER		WEIGHT kg/m		0.829
DESCRIPTION		DRAWING No.	SECTION No.	
PARTITION SECTION-SINGLE		4668	4668	
		11052	11052	
		20038	20038	