

4687

11039

20047

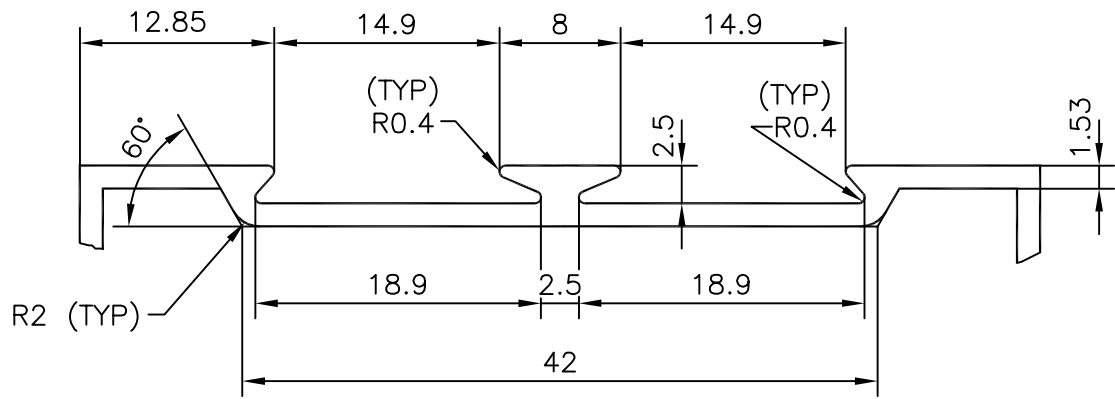

A (2:1)

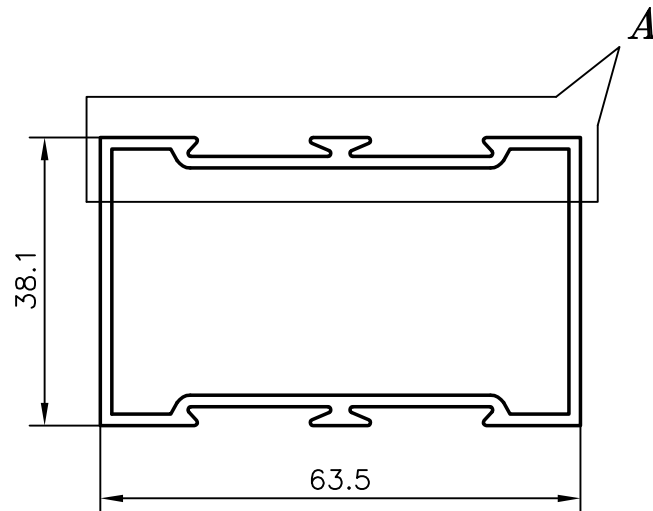

1. GENERAL WALL THICKNESS :- 1.53 mm.
2. 3658 mm. LONG PIECES IN 100 kgs :- 29 (AVERAGE)

JINDAL ALUMINIUM LTD.

BANGALORE-560073

JINDAL ALUMINIUM LTD. BANGALORE-560073		NAME		DATE	
		DRAWN		R.D.Sharma	
1. ALL DIMENSIONS ARE IN mm. 2. ROUND OFF ALL SHARP CORNERS WITH 0.4 mm. 3. TOLERANCES WILL BE AS PER IS: 6477-1983 ,UNLESS OTHERWISE SPECIFIED		CHECKED			
		APPROVED			
PARTY'S NAME		GENERAL CATEGORY		SCALE	
PARTY'S DRAWING No.		-		1:1 & 2:1	
ALLOY & TEMPER		HE9 WP		WEIGHT kg/m	
LENGTH		3658 mm.		0.942	
DESCRIPTION		PARTITION SECTION		SECTION No.	
				20047	
				DRAWING No.	
				20047	