

4694

11042

20053

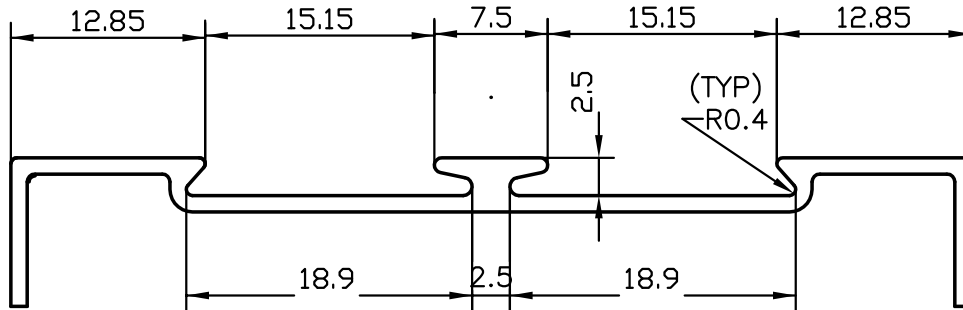

A (2:1)

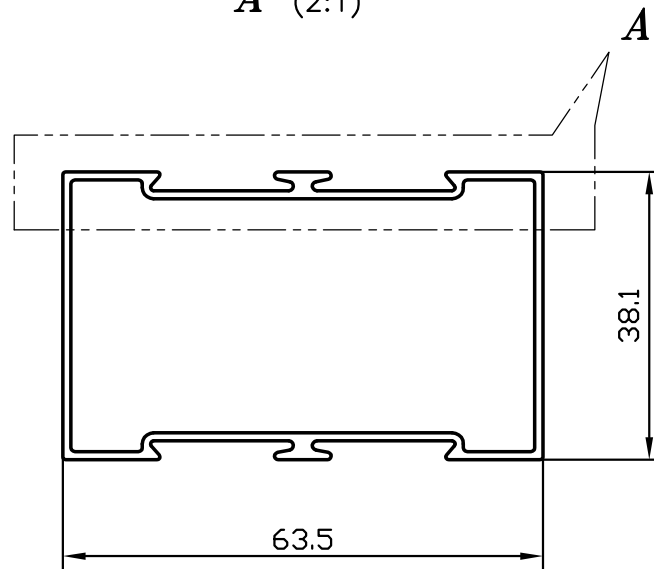

1. GENERAL WALL THICKNESS :- 1.08 mm.
2. 3658 mm. LONG PIECES IN 100 kgs :- 40 (AVERAGE)



SYMBOL OF QUALITY
AN ISO 9001 COMPANY

JINDAL ALUMINIUM LTD.
BANGALORE-560073 (INDIA)

	NAME	DATE
DRAWN	D.K Shaw	20-10-03
CHECKED		
APPROVED		

1. ALL DIMENSIONS ARE IN mm.
2. ROUND OFF ALL SHARP CORNERS WITH 0.40 mm.
3. TOLERANCES WILL BE AS PER IS: 6477-1983 UNLESS OTHERWISE SPECIFIED

SCALE	1:1
AREA mm ²	254.6
PERIMETER mm.	242.84
WEIGHT kg/m	0.686

PARTY'S NAME	GENERAL CATEGORY	DRAWING No.	SECTION No.
PARTY'S DRAWING No.	-	4694	4694
ALLOY & TEMPER	HE9 WP	11042	11042
		20053	20053
DESCRIPTION	PARTITION SECTION		