

2901

11073

20057

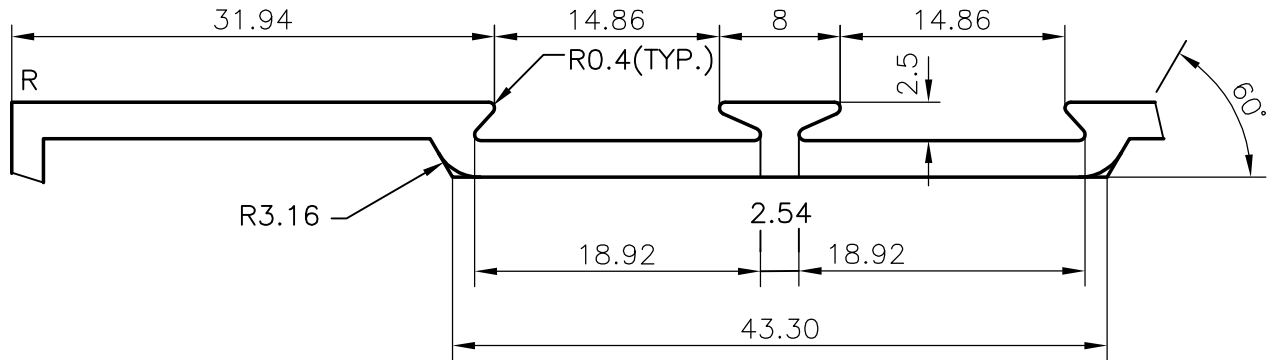

DETAILS - A (2:1)

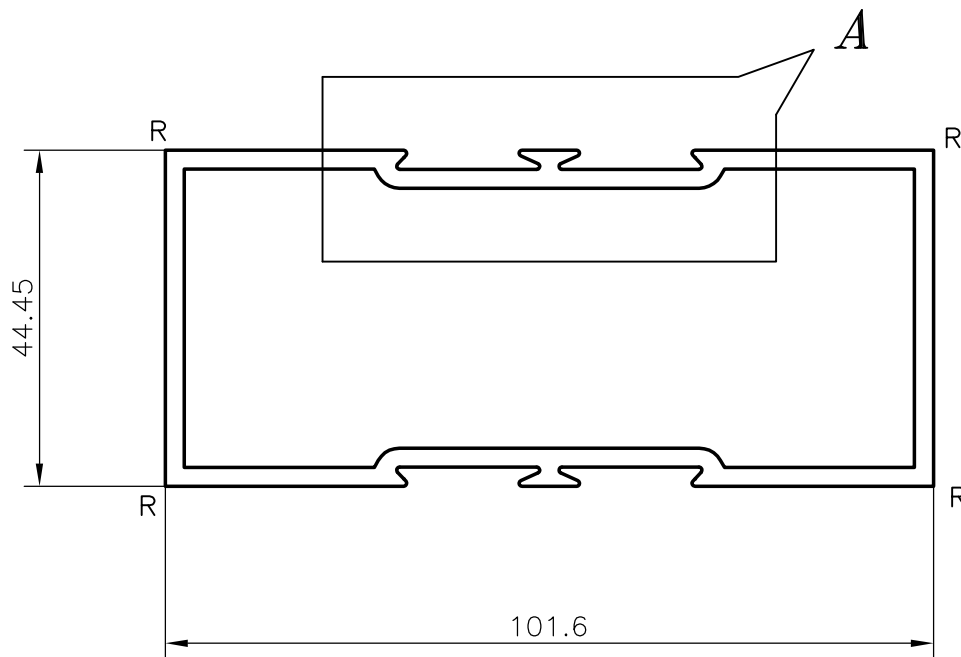

GENERAL WALL THICKNESS:- 2.5 mm.
R = 0.60 mm. (4 NO.)

JINDAL ALUMINIUM LTD.
BANGALORE-560073

		NAME	DATE
		DRAWN	D.SRIVASTAVA
1. ALL DIMENSIONS ARE IN mm. 2. ROUND OFF ALL SHARP CORNERS WITH 0.4 mm. 3. TOLERANCES WILL BE AS PER IS: 6477-1983 ,UNLESS OTHERWISE SPECIFIED		CHECKED	
		APPROVED	
PARTY'S NAME	GENERAL CATEGORY, CHENNAI MARKET	SCALE	1:1 & 2:1
PARTY'S DRAWING No.	NIL	WEIGHT kg/m	2.05
ALLOY & TEMPER	HE9 WP	SECTION No.	20057
LENGTH	3658mm	DRAWING No.	
DESCRIPTION	PARTITION SECTION	20057	