

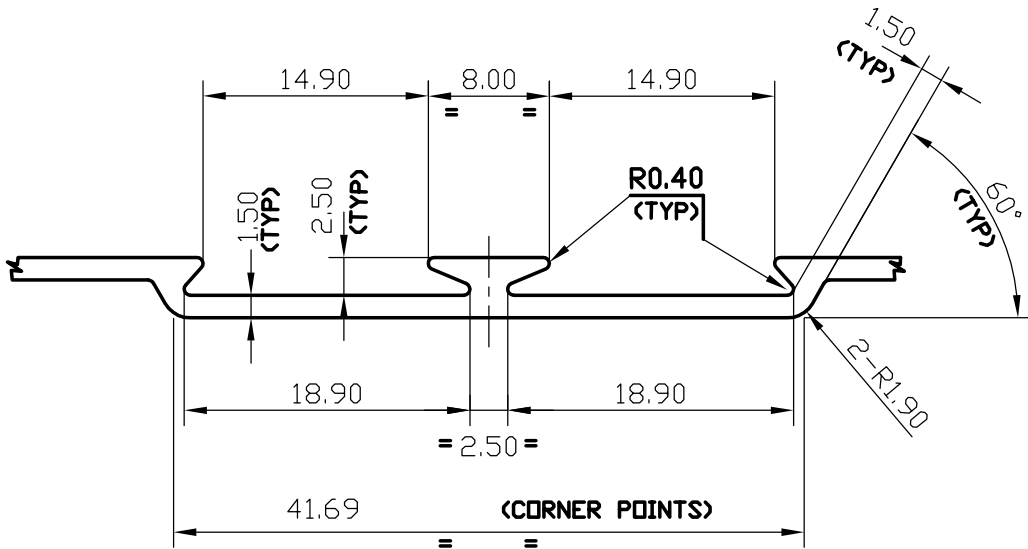

S410  
2903  
11111  
20059

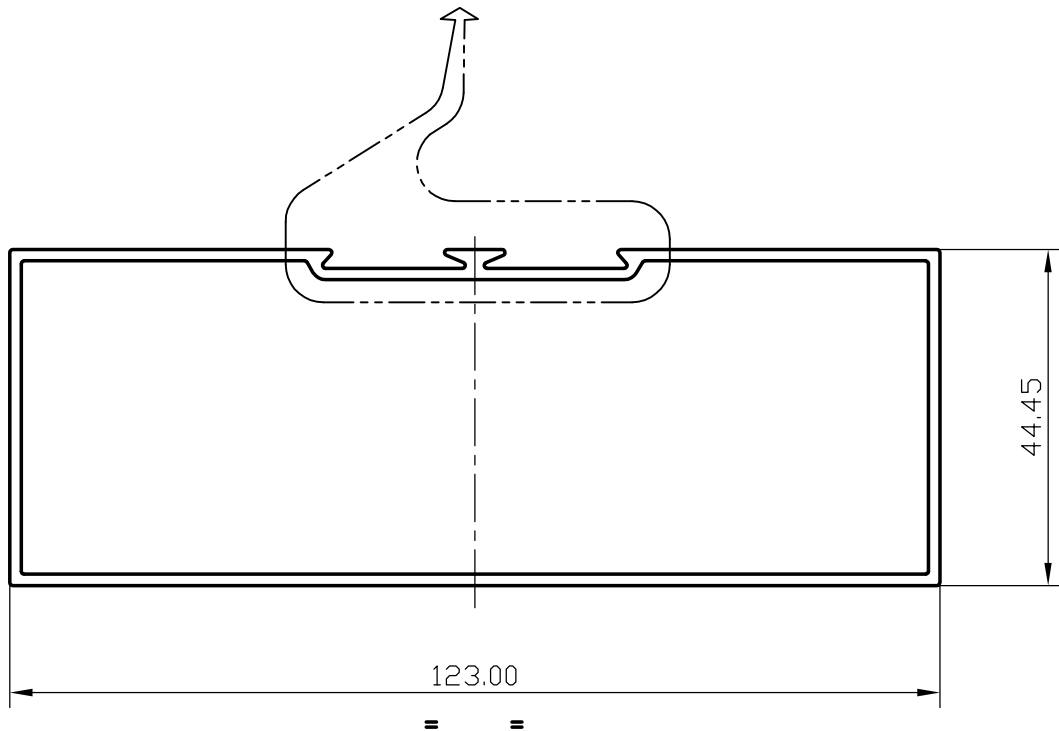

SCALE 2:1



1. GENERAL WALL THICKNESS 1.50 mm.

 SYMBOL OF QUALITY AN ISO 9002 COMPANY	<b>JINDAL ALUMINIUM LTD.</b> BANGALORE-560073 (INDIA)		NAME	DATE
			DRAWN	P,KULKARNI
1. ALL DIMENSIONS ARE IN mm. 2. ROUND OFF ALL SHARP CORNERS WITH 0.40 mm. 3. TOLERANCES WILL BE AS PER IS 6477-1983 UNLESS OTHERWISE SPECIFIED			CHECKED	
			APPROVED	
			SCALE	1:1
PARTY'S NAME	<b>MARVEL TOUCH ALUMINIUM PVT LTD.,          NAVI MUMBAI</b>		WEIGHT kg/m	1.394
PARTY'S DRAWING No.	<b>4617(4656) JAL MODIFIED.</b>		SECTION No.	20059
ALLOY & TEMPER	<b>HE9 WP</b>	LENGTH : <b>AS REQ</b>	DRAWING No.	
DESCRIPTION	<b>SINGLE PARTITION SECTION</b>		20059	