

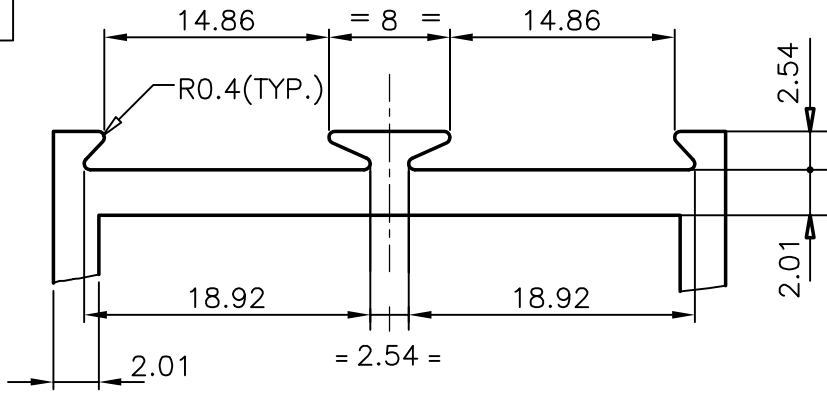

| |
|-------|
| 2904 |
| 11082 |
| 20060 |
| |

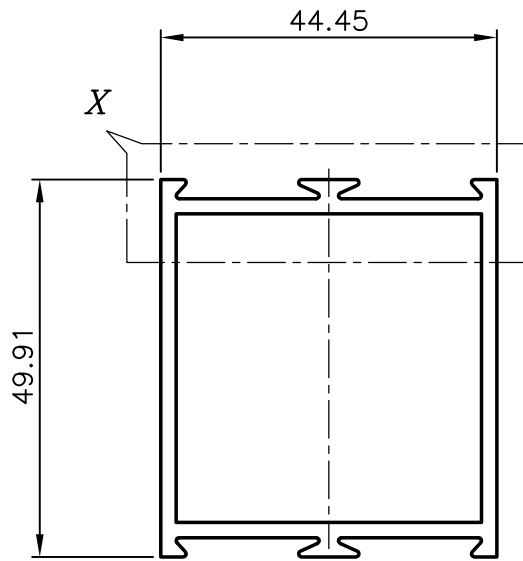

DETAIL AT "X"
2:1



AVERAGE WEIGHT 4.90 Kgs/15 Ft (4572 mm)
GENERAL WALL THICKNESS 2.01 mm

| | | | |
|--|--|----------------------|---------------------|
|  SYMBOL OF QUALITY AN ISO 9002 COMPANY | JINDAL ALUMINIUM LTD. BANGALORE-560073 (INDIA) | NAME | DATE |
| | | DRAWN | P,KULKARNI 4-4-2000 |
| 1. ALL DIMENSIONS ARE IN mm. 2. ROUND OFF ALL SHARP CORNERS WITH 0.40 mm. 3. TOLERANCES WILL BE AS PER I.S. 6477-1983 UNLESS OTHERWISE SPECIFIED | | CHECKED | |
| | | APPROVED | |
| | | SCALE | 1:1 |
| PARTY'S NAME | GENERAL CATEGORY (DELHI MARKET) | WEIGHT kg/m | 1.072 |
| PARTY'S DRAWING No. | LIGHTER OF SEC No 4621 | SECTION No. | 20060 |
| ALLOY & TEMPER | HE9 WP | DRAWING No. 20060 | |
| DESCRIPTION | PARTITION SECTION (DOUBLE) | | |