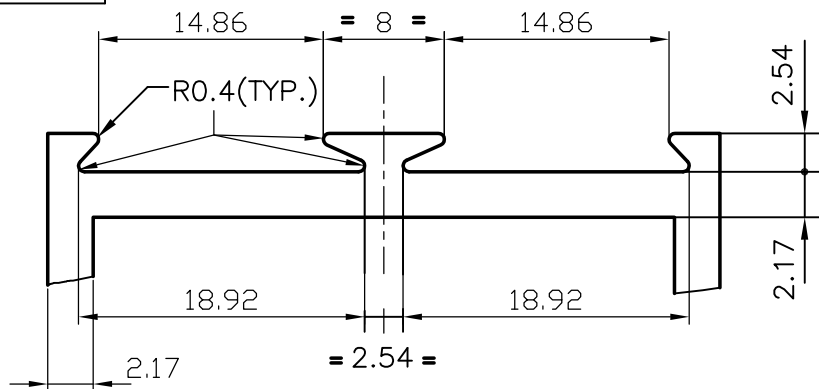

2905

10532

20061

*DETAIL AT "X"*

2:1

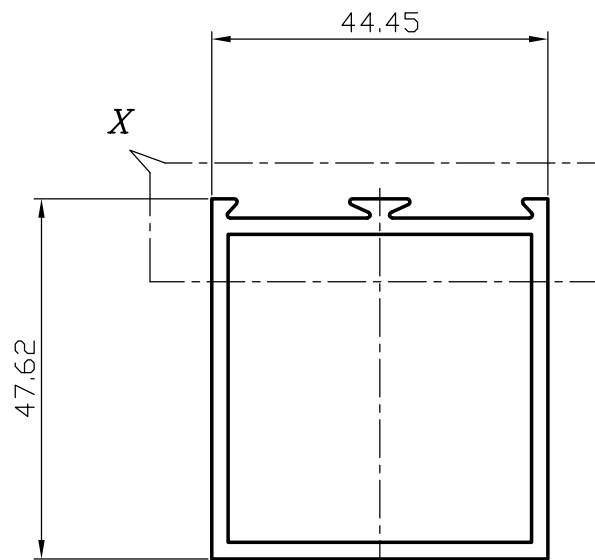

AVERAGE WEIGHT 4.90 Kgs/15 Ft (4572 mm)

GENERAL WALL THICKNESS 2.17 mm



SYMBOL OF QUALITY  
AN ISO 9002 COMPANY

**JINDAL ALUMINIUM LTD.**  
BANGALORE-560073 (INDIA)

	NAME	DATE
DRAWN	P,KULKARNI	4-4-2000
CHECKED		
APPROVED		

SCALE	1:1
-------	-----

WEIGHT kg/m	1.072
-------------	-------

SECTION No.	20061
-------------	-------

DRAWING No.	20061
-------------	-------

1. ALL DIMENSIONS ARE IN mm.
2. ROUND OFF ALL SHARP CORNERS WITH 0.40 mm.
3. TOLERANCES WILL BE AS PER I.S. 6477-1983 UNLESS OTHERWISE SPECIFIED

PARTY'S NAME	GENERAL CATEGORY (DELHI MARKET)
--------------	---------------------------------

PARTY'S DRAWING No.	LIGHTER OF SEC No 4531
---------------------	------------------------

ALLOY & TEMPER	HE9 WP
----------------	--------

DESCRIPTION	PARTITION SECTION (SINGLE)
-------------	----------------------------