

2915

11040

20062

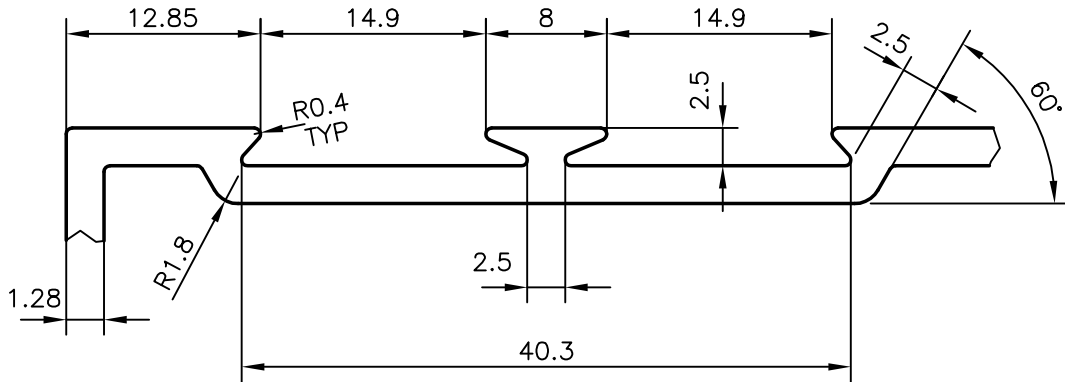

DETAILS - A (2:1)

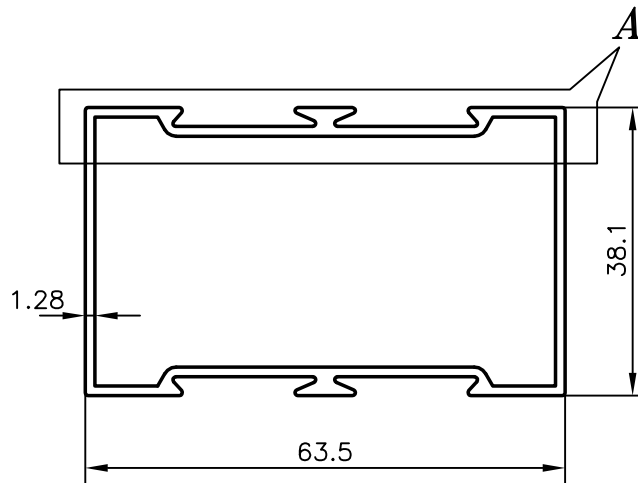

GENERAL WALL THICKNESS :- 1.28 mm.



SYMBOL OF QUALITY  
AN ISO 9001 COMPANY

**JINDAL ALUMINIUM LTD.**  
BANGALORE-560073 (INDIA)

	NAME	DATE
DRAWN	RAGHAVENDRA	30-10-2006
CHECKED		
APPROVED		

1. ALL DIMENSIONS ARE IN mm.
2. ROUND OFF ALL SHARP CORNERS WITH 0.40 mm.
3. TOLERANCES WILL BE AS PER IS:6477-1983 UNLESS OTHERWISE SPECIFIED

SCALE	1:1
AREA mm <sup>2</sup>	298.148
PERIMETER mm.	244.349
WEIGHT kg/m	0.805

PARTY'S NAME	GENERAL CATEGORY, COCHIN
PARTY'S DRAWING No.	NIL
ALLOY & TEMPER	HE9 WP
DESCRIPTION	PARTITION SECTION - DOUBLE

DRAWING No.	SECTION No.
2915	2915
11040	11040
20062	20062