

2916

11025

20063

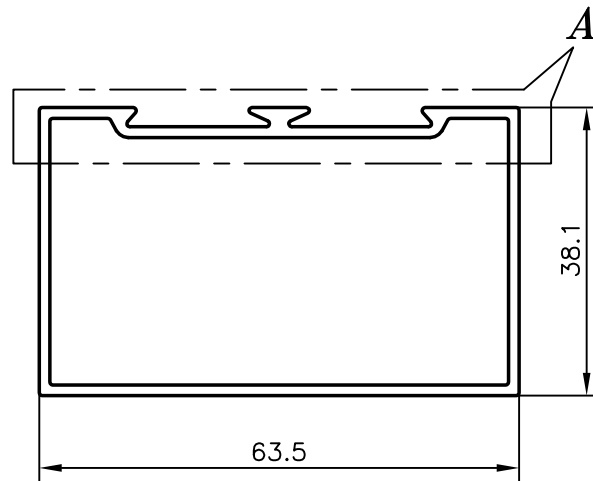
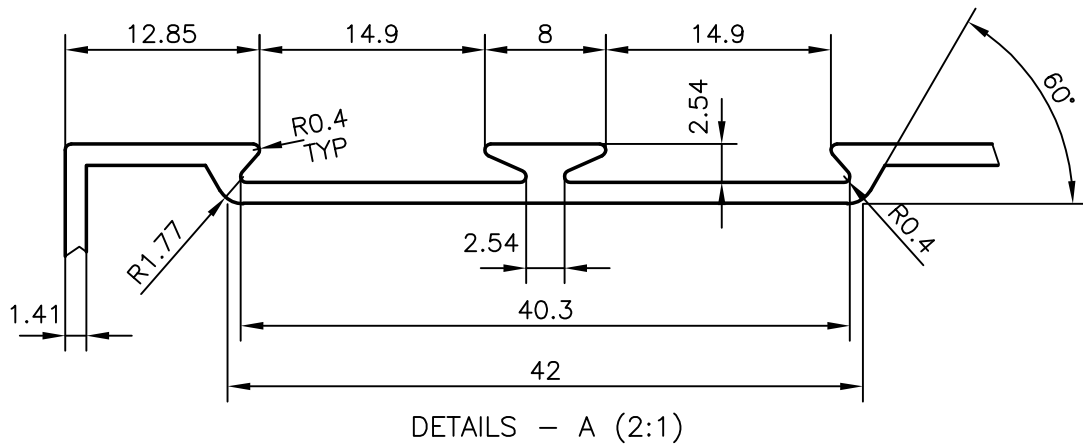

1. GENERAL WALL THICKNESS :- 1.41 mm.
2. WEIGHT PER PIECE :- 3.0 kg



SYMBOL OF QUALITY
AN ISO 9001 COMPANY

JINDAL ALUMINIUM LTD.
BANGALORE-560073 (INDIA)

	NAME	DATE
DRAWN	RAGHAVENDRA	24-10-2006
CHECKED		
APPROVED		

1. ALL DIMENSIONS ARE IN mm.
2. ROUND OFF ALL SHARP CORNERS WITH 0.40 mm.
3. TOLERANCES WILL BE AS PER IS:6477-1983 UNLESS OTHERWISE SPECIFIED

SCALE	1:1
AREA mm ²	302.844
PERIMETER mm.	223.446
WEIGHT kg/m	0.818

PARTY'S NAME GENERAL CATEGORY, COCHIN MARKET

PARTY'S DRAWING No. NIL

ALLOY & TEMPER HE9 WP

DESCRIPTION PARTITION SECTION - SINGLE

DRAWING No.	SECTION No.
2916	2916
11025	11025
20063	20063