

2921

11037

20064

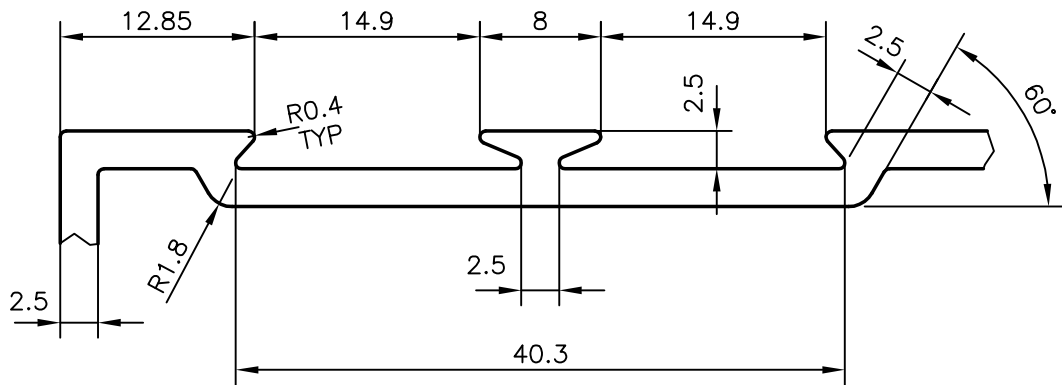

DETAILS - A (2:1)

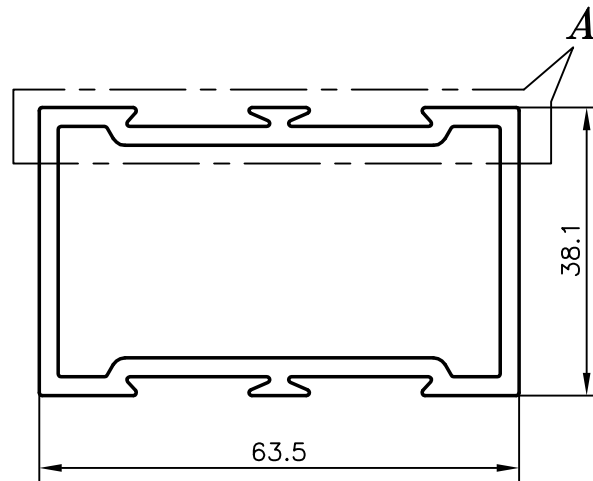

GENERAL WALL THICKNESS :- 2.5 mm.



SYMBOL OF QUALITY
AN ISO 9001 COMPANY

JINDAL ALUMINIUM LTD.
BANGALORE-560073 (INDIA)

	NAME	DATE
DRAWN	MAHALINGAPPA	22-09-2005
CHECKED		
APPROVED		

1. ALL DIMENSIONS ARE IN mm.
2. ROUND OFF ALL SHARP CORNERS WITH 0.40 mm.
3. TOLERANCES WILL BE AS PER IS:6477-1983 UNLESS OTHERWISE SPECIFIED

SCALE	1:1
AREA mm ²	534.798
PERIMETER mm.	244.349
WEIGHT kg/m	1.444

PARTY'S NAME	GENERAL CATEGORY, CALCUTTA MARKET
PARTY'S DRAWING No.	AS PER SPECIFICATION (SAMPLE NO. 9207)
ALLOY & TEMPER	HE9 WP
DESCRIPTION	PARTITION SECTION - DOUBLE

DRAWING No.	SECTION No.
2921	2921
11037	11037
20064	20064