

2924

11062

20067

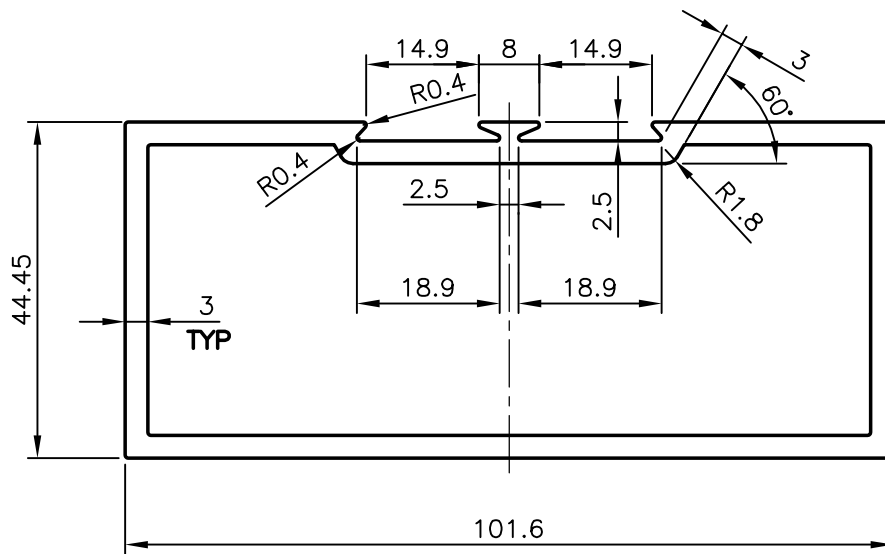

GENERAL WALL THICKNESS = 3.00mm



SYMBOL OF QUALITY  
AN ISO 9001 COMPANY

**JINDAL ALUMINIUM LTD.**  
BANGALORE-560073 (INDIA)

	NAME	DATE
DRAWN	RAGHAVENDRA	12-12-2006
CHECKED		
APPROVED		

1. ALL DIMENSIONS ARE IN mm.
2. ROUND OFF ALL SHARP CORNERS WITH 0.40 mm.
3. TOLERANCES WILL BE AS PER IS:6477-1983 UNLESS OTHERWISE SPECIFIED

SCALE	1:1
AREA mm <sup>2</sup>	867.659
PERIMETER mm.	312.503
WEIGHT kg/m	2.343

PARTY'S NAME	GENERAL CATEGORY., CALCUTTA MARKET
PARTY'S DRAWING No.	AS PER SPECIFICATION (SAMPLE NO. 9205)
ALLOY & TEMPER	HE9 WP
DESCRIPTION	PARTITION SECTION - SINGLE GROOVE

DRAWING No.	SECTION No.
2924	8730
11062	11062
20067	20067