

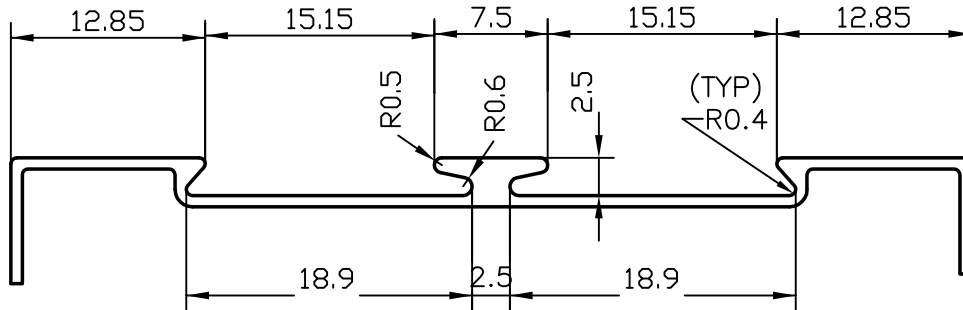

P-3455
2928
11029
20068

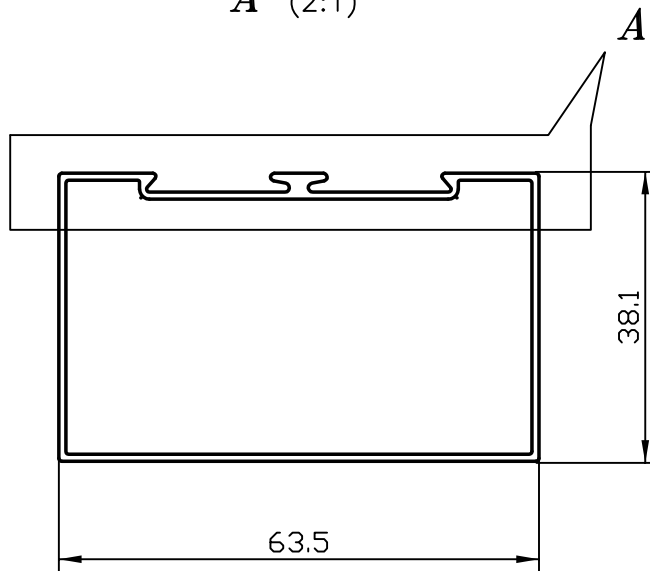

A (2:1)



1. GENERAL WALL THICKNESS :- 0.92 mm.
2. 3658 mm. LONG PIECES IN 100 kgs :- 50 (AVERAGE)

 SYMBOL OF QUALITY AN ISO 9001 COMPANY	JINDAL ALUMINIUM LTD. BANGALORE-560073 (INDIA)	NAME		DATE
		DRAWN	D.K Shaw	20-10-03
1. ALL DIMENSIONS ARE IN mm. 2. ROUND OFF ALL SHARP CORNERS WITH 0.40 mm. 3. TOLERANCES WILL BE AS PER IS: 6477-1983 UNLESS OTHERWISE SPECIFIED		CHECKED		
		APPROVED		
PARTY'S NAME GENERAL CATEGORY		SCALE		1:1
		AREA mm ²		201
PARTY'S DRAWING No. LIGHTER SECTION OF 4663		PERIMETER mm.		223.35
		WEIGHT kg/m		0.546
ALLOY & TEMPER HE9 WP		DRAWING No.		SECTION No.
		2928		2928
DESCRIPTION PARTITION SECTION		11029		11029
		20068		20068