

2942

10533

20071

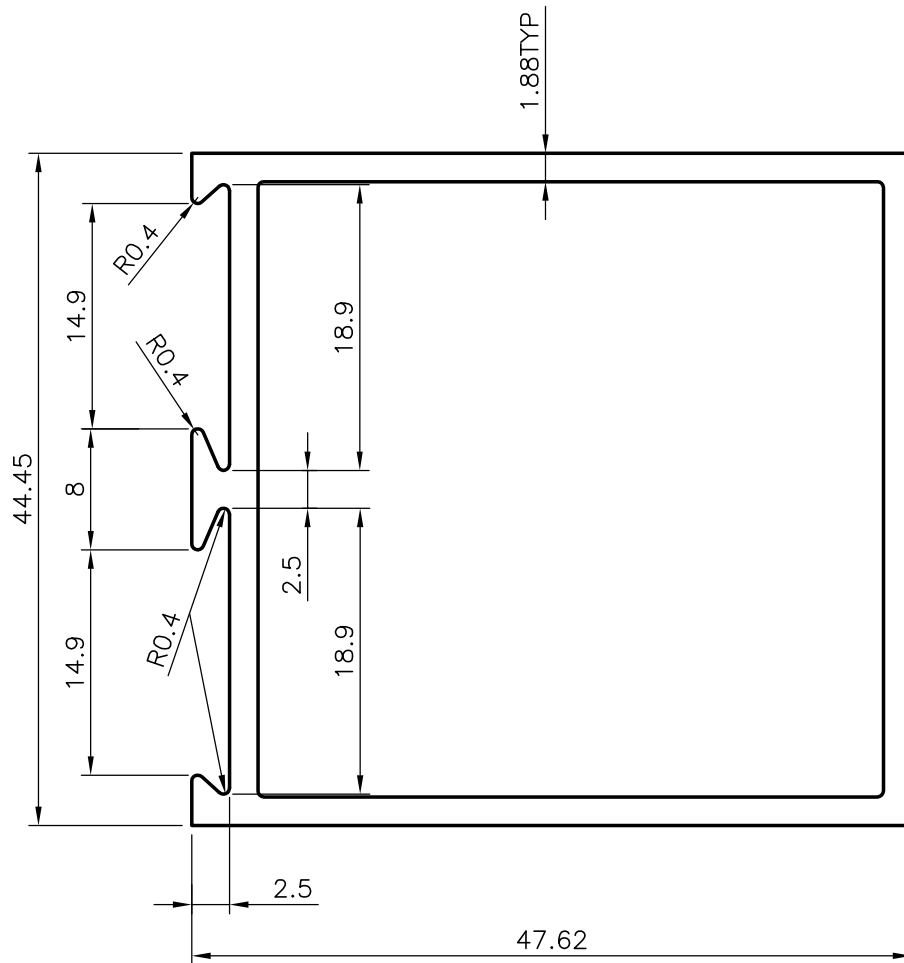
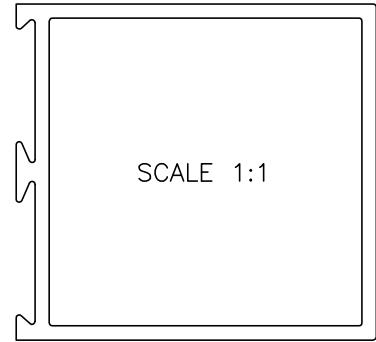

GENERAL WALL THICKNESS = 1.88 mm
NO. OF PIECES IN 100 kgs = 29 (AVERAGE)



SYMBOL OF QUALITY
AN ISO 9001 COMPANY

JINDAL ALUMINIUM LTD.
BANGALORE-560073 (INDIA)

	NAME	DATE
DRAWN	RAGHAVENDRA	23-12-2006
CHECKED		
APPROVED		

1. ALL DIMENSIONS ARE IN mm.
2. ROUND OFF ALL SHARP CORNERS WITH 0.40 mm.
3. TOLERANCES WILL BE AS PER IS:6477-1983 UNLESS OTHERWISE SPECIFIED

SCALE	2:1
AREA mm ²	349.339
PERIMETER mm.	204.714
WEIGHT kg/m	0.943

PARTY'S NAME	-	DRAWING No.	2942	SECTION No.	2942
PARTY'S DRAWING No.	LIGHTER SECTION OF 4531		10533		10533
ALLOY & TEMPER	HE9 WP		20071		20071
DESCRIPTION	DOOR SECTION				