

2945

11103

20074

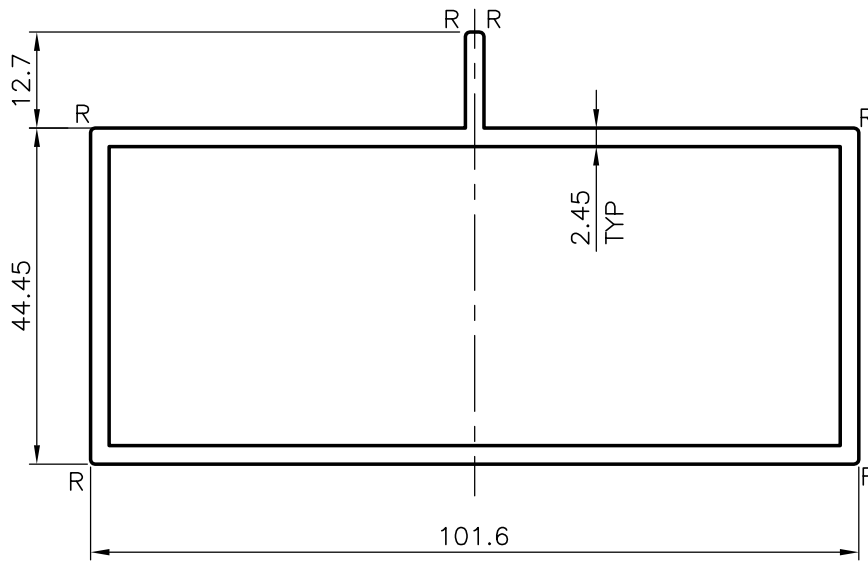

GENERAL WALL THICKNESS = 2.45mm

R = 0.60mm RADIUS (6 PLACES)

NO OF PIECES IN 100 kgs:- 14 (AVERAGE)



SYMBOL OF QUALITY
AN ISO 9001 COMPANY

JINDAL ALUMINIUM LTD.
BANGALORE-560073 (INDIA)

	NAME	DATE
DRAWN	RAGHAVENDRA	30-10-2006
CHECKED		
APPROVED		

1. ALL DIMENSIONS ARE IN mm.
2. ROUND OFF ALL SHARP CORNERS WITH 0.40 mm.
3. TOLERANCES WILL BE AS PER IS:6477-1983 UNLESS OTHERWISE SPECIFIED

SCALE	1:1
AREA mm ²	722.286
PERIMETER mm.	315.955
WEIGHT kg/m	1.951

PARTY'S NAME	-	DRAWING No.	SECTION No.
PARTY'S DRAWING No.	LIGHTER SECTION OF 20008	2945	2945
ALLOY & TEMPER	HE9 WP	11103	11103
		20074	20074
DESCRIPTION	PARTITION SECTION		