

2947

11075

20076

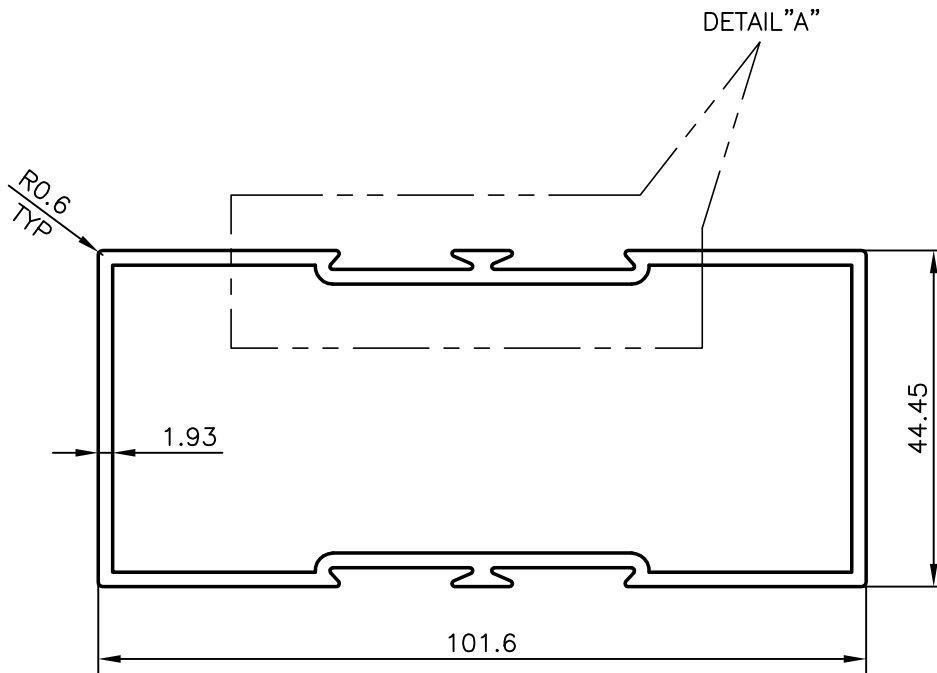
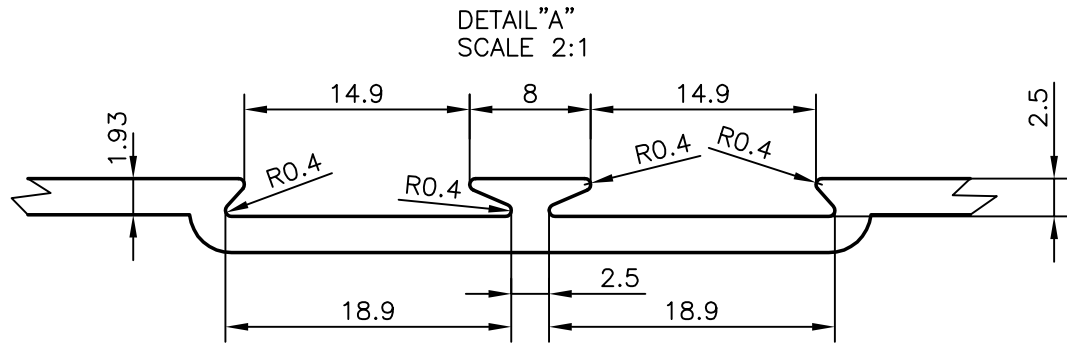

GENERAL WALL THICKNESS :- 1.93 mm.

NO. OF PIECES IN 100 kgs = 17 (AVERAGE)



SYMBOL OF QUALITY
AN ISO 9001 COMPANY

JINDAL ALUMINIUM LTD.
BANGALORE-560073 (INDIA)

	NAME	DATE
DRAWN	RAGHAVENDRA	13-09-2006
CHECKED		
APPROVED		

1. ALL DIMENSIONS ARE IN mm.
2. ROUND OFF ALL SHARP CORNERS WITH 0.40 mm.
3. TOLERANCES WILL BE AS PER IS:6477-1983 UNLESS OTHERWISE SPECIFIED

SCALE	1:1
AREA mm ²	595.683
PERIMETER mm.	332.905
WEIGHT kg/m	1.608

PARTY'S NAME	-	DRAWING No.	2947	SECTION No.	2947
PARTY'S DRAWING No.	LIGHTER SECTION OF 4616		11075		11075
ALLOY & TEMPER	HE9 WP		20076		20076
DESCRIPTION	PARTITION SECTION				